

SONY TCD-D3 OPERATING INSTRUCTIONS MANUAL



Table of Contents

[On Power Sources](#)

[On Moisture Condensation](#)

[Location And Function Of Controls](#)

[Power Sources](#)

[Nice to Know](#)

[How to Use the Carrying Case](#)

[Cleaning the Cabinet](#)

[Specifications](#)

[Troubleshooting Guide](#)

[Other ManualsLib Projects](#)

SONY

3-752-456-25 (1)

Digital Audio Tape-corder

TCD-D3

Operating Instructions

Before operating the unit, please read this manual thoroughly and retain it for future reference.

Owner's Record

The model and serial numbers are located on the bottom. Record the serial number in the space provided below. Refer to them whenever you call upon your Sony dealer regarding this product.

Model No. TCD-D3

Serial No. _____

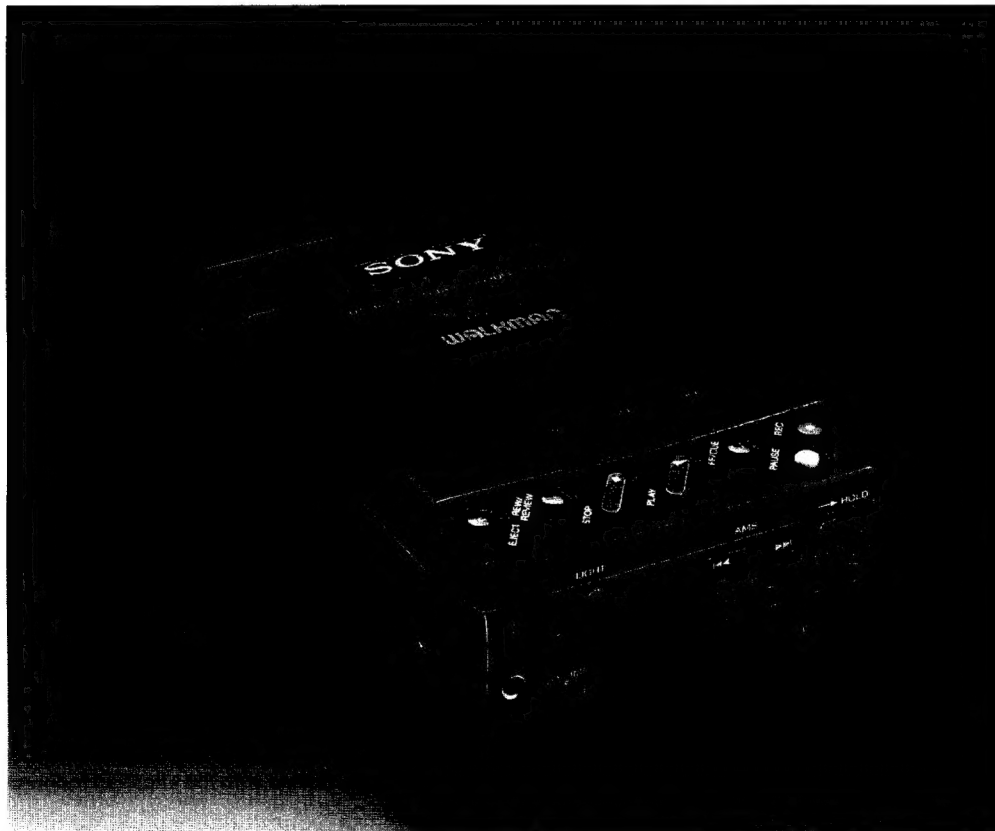

Warning

To prevent fire or shock hazard, do not expose the unit to rain or moisture.

To avoid electrical shock, do not open the cabinet. Refer servicing to qualified personnel only.

NOTICE FOR THE CUSTOMERS IN THE UNITED KINGDOM

IMPORTANT

The wires in this mains lead are coloured in accordance with the following code;

Blue: Neutral

Brown: Live

As the colours of the wires in the mains lead of this apparatus may not correspond with the coloured markings identifying the terminals in your plug proceed as follows:

The wire which is coloured blue must be connected to the terminal which is marked with the letter N or coloured black.

The wire which is coloured brown must be connected to the terminal which is marked with the letter L or coloured red.

Do not connect either wire to the earth terminal in the plug which is marked by the letter E or by the safety earth symbol \perp or coloured green or green-and-yellow.

INFORMATION

This equipment generates and uses radio frequency energy and if not installed and used properly, that is, in strict accordance with the manufacturer's instructions, may cause interference to radio and television reception. It has been type tested and found to comply with the limits for a Class B computing device in accordance with the specifications in Subpart J of Part 15 of FCC Rules, which are designed to provide reasonable protection against such interference in a residential installation. However, there is no guarantee that interference will not occur in a particular installation. If this equipment does cause interference to radio or television reception, which can be determined by turning the equipment off and on, the user is encouraged to try to correct the interference by one or more of the following measures:

Reorient the receiving antenna

Relocate the equipment with respect to the receiver

Move the equipment away from the receiver

Plug the equipment into a different outlet so that equipment and receiver are on different branch circuits.

If necessary, the user should consult the dealer or an experienced radio/television technician for additional suggestions. The user may find the following booklet prepared by the Federal Communications Commission helpful:

"How to Identify and Resolve Radio-TV Interference Problems". This booklet is available from the U.S. Government Printing Office, Washington, DC 20402, Stock No. 004-000-00345-4.

Features

Application of the serial copy management system

This unit utilizes a serial copy management system which permits digital-to-digital recording for one generation. You can record CD sound or other digital formats through a digital-to-digital connection.

Three sampling frequencies

Recording/playback can be done with three sampling frequencies 48 kHz, 44.1 kHz and 32 kHz.

48 kHz: For analog input signals in a standard mode and 48 kHz, digital audio signals.

44.1 kHz: For digital input of compact disc and pre-recorded DAT tape.

32 kHz: For analog input signals in a long-play mode and 32 kHz digital audio signals.

Capability for recording an analog signal source

MIC/LINE IN jack on the unit in addition to digital input/output allows recording of an analog signal source from a microphone or line output signal from stereo system.

Excellent sound quality

Excellent sound quality through a built-in over sampling digital filter.

Miniaturized digital audio tape recorder

The newly-developed miniaturized mechanism and ICs make possible this very small digital audio tape recorder.

Long play mode

This unit can operate in a long play mode. Analog input signals or 32 kHz digital signals can be recorded or played back for up to four consecutive hours when the DT-120 DAT cassette tape is used. The sampling frequency will be 32 kHz in the long play mode.

Post edit recording of start ID and program numbers

You can record or rewrite the start ID and program numbers after the audio signal recording has been completed.

Locating the beginning of the selection at high speed.

Liquid crystal display with a back-light system.

Approximately two-hour continuous recording and playing is possible with the supplied rechargeable battery.

AC power adaptor which can be used during charging is supplied.

Table of Contents

| | |
|--------------------------------------------------|-----------|
| Features | 2 |
| Guide to the Serial Copy Management System | 4 |
| Precautions | 6 |
| Location and Function of Controls | 8 |
| Power Sources | 1- |
| To Record | 15 |
| Connection with other equipment | 15 |
| Tape insertion | 21 |
| Recording | 22 |
| To Play Back | 25 |
| Connection with other equipment | 26 |
| Playback | 27 |
| Locating the beginning of the selection | 29 |
| Display window | 29 |
| Nice to Know | 29 |
| On start ID | 29 |
| Writing start ID manually during recording | 29 |
| Writing start ID manually during playback | 29 |
| Erasing start ID | 30 |
| On program numbers | 31 |
| Renumbering program numbers | 31 |
| Erasing a program number | 31 |
| How to Use the Carrying Case | 32 |
| Maintenance | 32 |
| Specifications | 33 |
| Troubleshooting Guide | 34 |

Guide to the Serial Copy Management System

What is the Serial Copy Management System

This system permits one generation of digital recording of prerecorded software via the digital input/output. A summary of the rules which this system encompasses is as follows:

1

You can record a compact disc onto a digital audio tape via digital input/output to make a first generation type. But you cannot record the recorded tape onto another via the digital input/output.

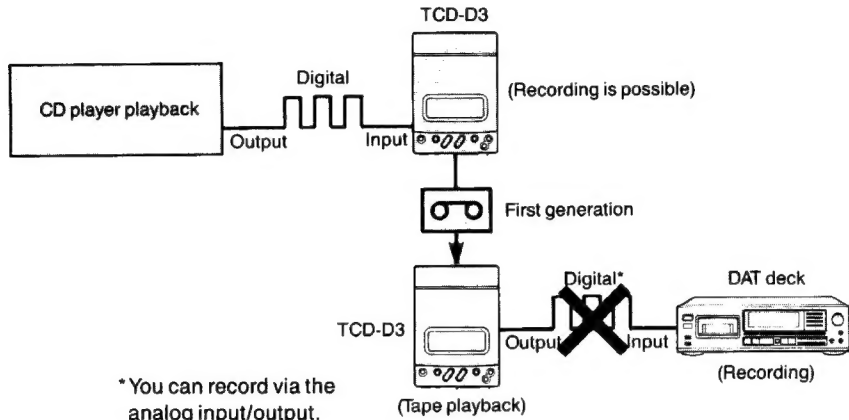

2

You can record a prerecorded digital audio tape onto a digital audio tape as one generation via the digital input/output. But you cannot record the recorded tape onto another via the digital input/output.

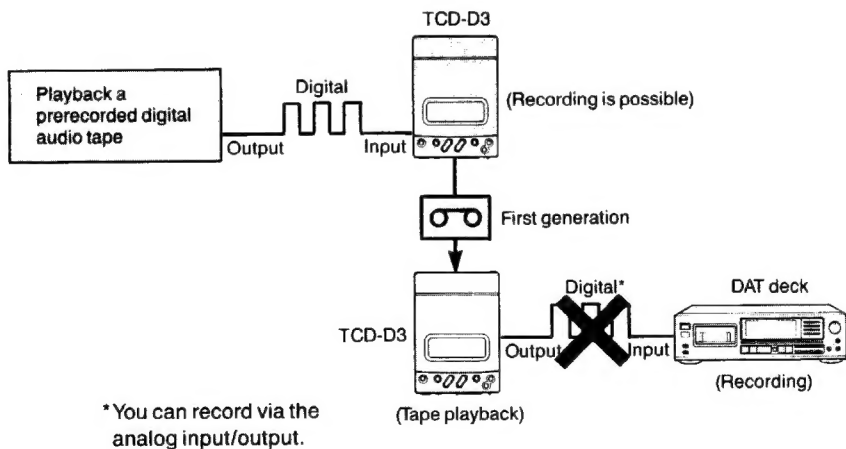

Note

The Serial Copy Management System may not apply to some digital audio tape decks.

3

You can record a digital signal from a BS tuner to a digital audio tape to make a second generation via digital input/output. Some BS tuner may not be applicable to the above principle.

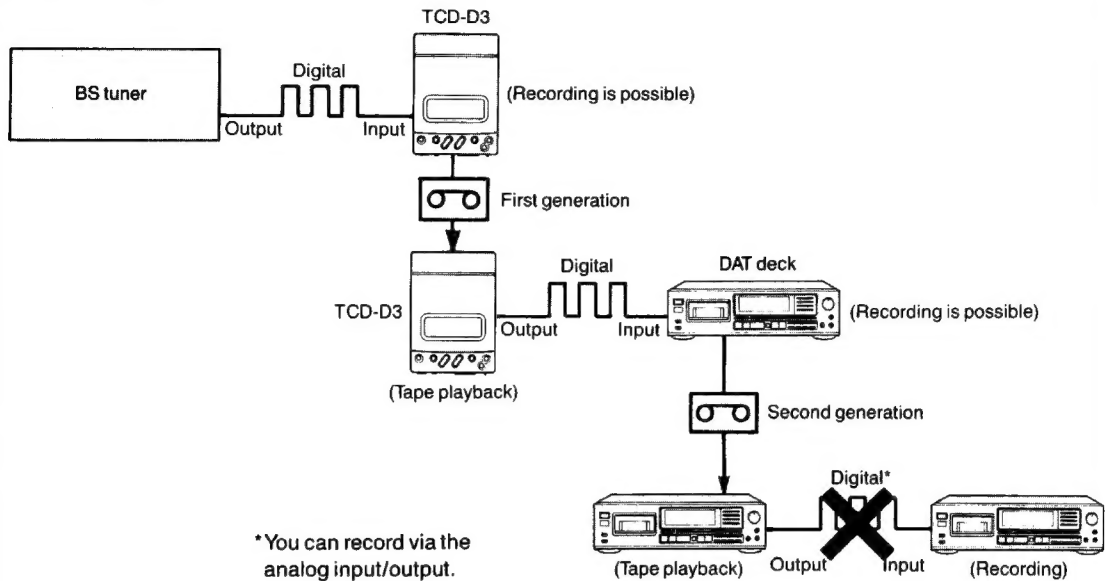

4

You can record a digital audio tape which has been recorded from analog input onto another digital audio tape to make a second generation via the digital input/output. But you cannot record the second generation tape to another via the digital input/output.

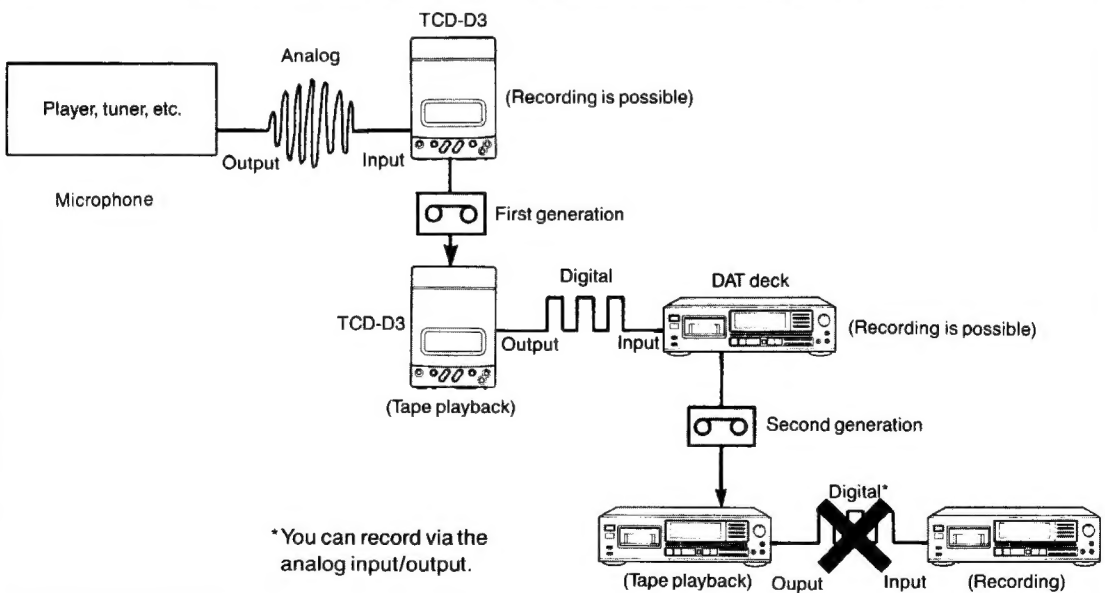

Notes

There are no restrictions for generation when DAT decks are connected via the analog input/output. Therefore, you can record any audio source onto a digital audio tape via the analog input/output even when you cannot record them via digital input/output.

Precautions

On Safety

- The unit is not disconnected from the AC power source (mains) as long as it is connected to the wall outlet, even if the unit itself has been turned off.
- Should any solid object or liquid fall into the cabinet, unplug the unit and have it checked by qualified personnel before operating it any further.
- Unplug the unit from the wall outlet if it is not to be used for an extended period of time. To disconnect the cord, pull it out by grasping the plug. Never pull the cord itself.
- Do not put anything in the DC IN 9 V (external power input) jack.

On Power Sources

- Use the supplied rechargeable battery pack or house current.
- For AC operation: Use the AC power adaptor supplied with this unit.
Do not use any other AC power adaptor as it may cause malfunction.
For car battery operation: Use the car mount arm CPM-D3 (not supplied) equipped with a car battery cord or the car battery cord DCC-E190L (not supplied).
- When the unit will not be used for a long time, be sure to disconnect the power source (AC power adaptor, rechargeable battery pack, car battery cord or mount plate) from the unit. To remove the AC power adaptor from the wall outlet, grasp the adaptor itself; never pull it by the cord.

On Installation

- Do not install the unit in a location near heat sources such as radiators or air ducts, or in a place subject to direct sunlight, excessive dust, mechanical vibration or shock.
- Do not place anything on the top of the cabinet. The top ventilation holes must be unobstructed for the proper operation of the unit and to prolong the life of its components.

On Moisture Condensation

If the unit is brought directly from a cold to a warm location, moisture may condense inside the unit. In this condition, the tape may adhere to the head drum and be damaged, or the unit may not operate correctly. Always remove the cassette when the unit will not be used.

If moisture is present . . .

- Function controls will not operate.
- All operations will stop.

When the CAUTION Indicator lights and the unit will not operate

Leave the unit turned on for about an hour.

On Supplied Digital Cable

- Turn off the power of the unit before you connect the cable to it.
- The minimum radius of the cable when coiled is 25mm.
- Do not drop any heavy object on the cable.
- To disconnect the cable, pull it out by the plug. Never pull the cable itself.
- The optical plugs are designed to prevent connection to the optical transmission module upside down. Whenever you plug them in, make sure they are right side up.
- Keep the surface of the terminals of the connectors clean. When they become soiled, wipe them gently with clean tissue or cotton, moistened with ethyl alcohol. Do not use any other type of solvent except ethyl alcohol. (Sony KK-9 cleaning kit is available.)
- Remove the caps of the rectangular-shaped, optical input/output connectors when you use the cable.
- When you put away the cable, do not fold nor bend it since it contains an optical fiber.

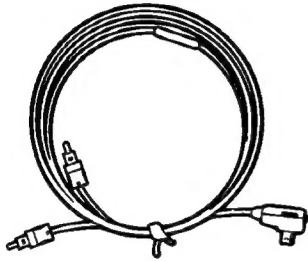

Secure with string, wire, etc.

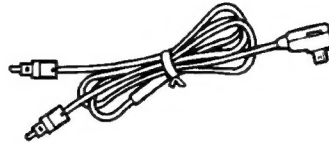

Do not tie the cable itself.

If you have any question or problem concerning your unit, please consult your nearest Sony dealer.

Location and Function of Controls

▶ PLAY button

Press to play back the tape or to check the sampling frequency in the display window during playback or recording.

■ STOP button

Press to stop recording or playback.

◀◀ REW/REVIEW button

In the stop mode, press to rewind the tape. During playback, press to rewind the tape while listening to the sound.

▲ EJECT button

Press when inserting or removing the cassette. This functions as long as when a power source—AC power adaptor, battery pack—is connected even if the power switch is set to off.

▶▶ FF/CUE button

In the stop mode, press to fast-forward the tape. During playback or recording, press to fast-forward the tape while listening to the sound.

|| PAUSE button

Press to stop for a moment during recording or playback. To restart recording or playback, press this button again or press ▶.

If the unit is left in the pause mode for about 5 minutes, it will be automatically released and the deck will enter the stop mode. To restart recording or playback from the stop mode, press REC and ▶ PLAY at the same time when recording or press ▶ PLAY when playing back.

● REC (recording) button

Press to start recording or to monitor the input signal.

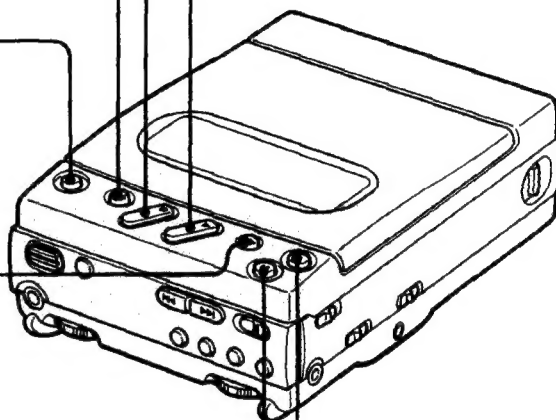

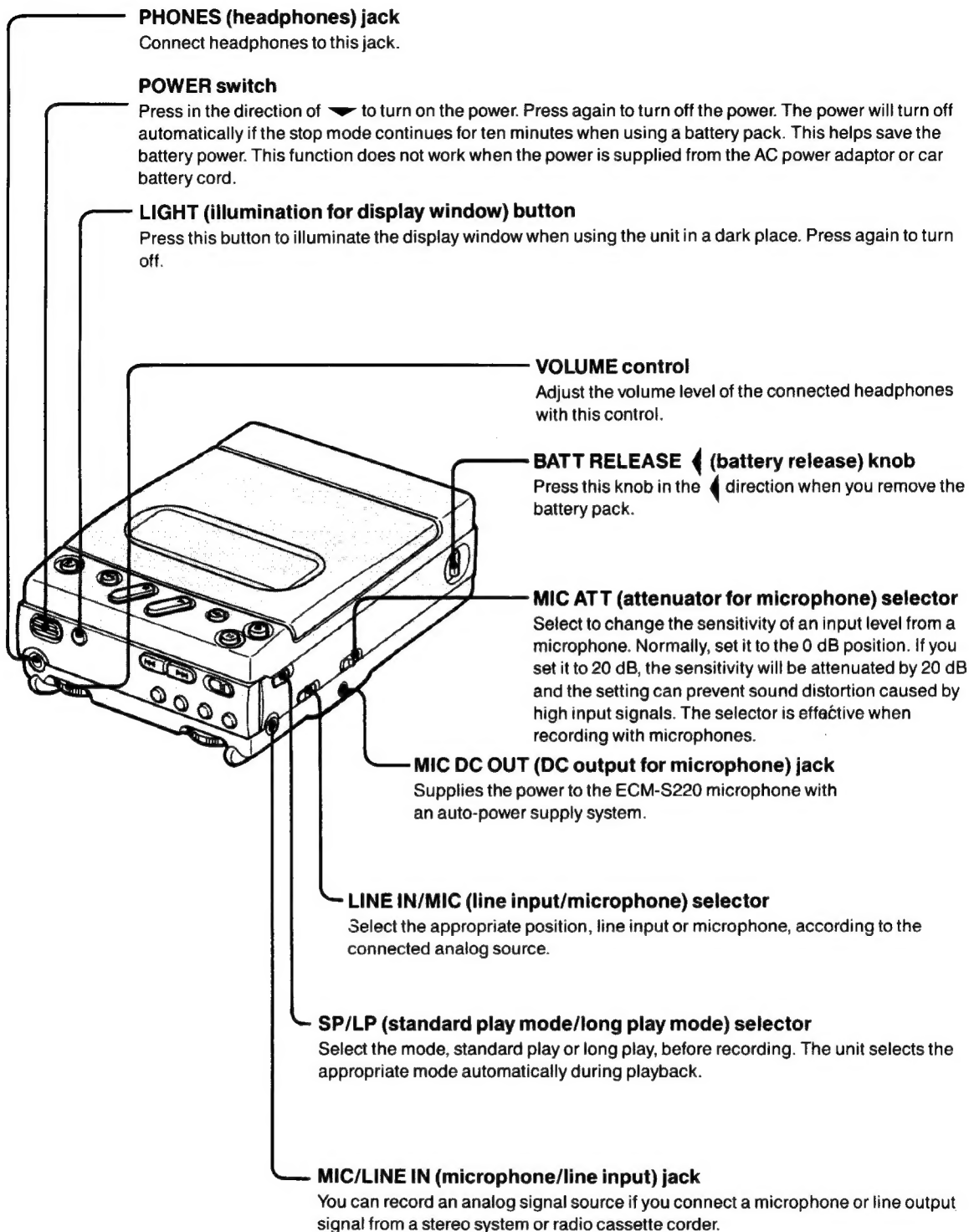

Location and Function of Controls

DC IN 9 V (DC 9 V input) jack

Connect the supplied AC power adaptor or car battery cord to this jack.

LINE OUT (line output) jack

Connect equipment which has a line input jack to this jack. VOLUME control does not affect the signal from this jack.

REMOTE, DIGITAL I/O (remote, digital input/output) jack

Connect equipment which has digital input/output with a POC-DA12 cable (supplied) or RK-DA10 cable (not supplied) or an RM-D3K adaptor kit (not supplied) to this jack.

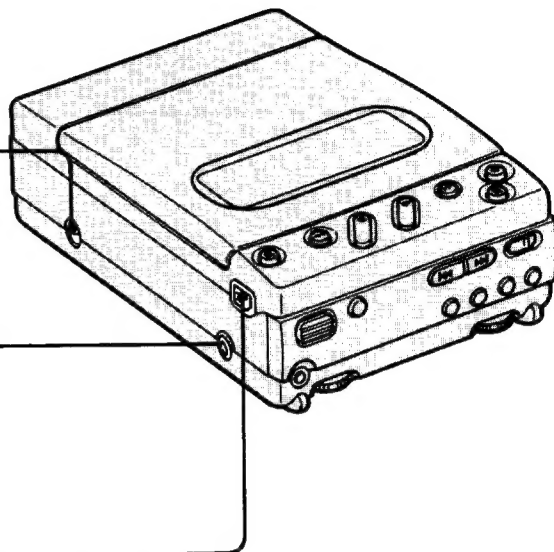

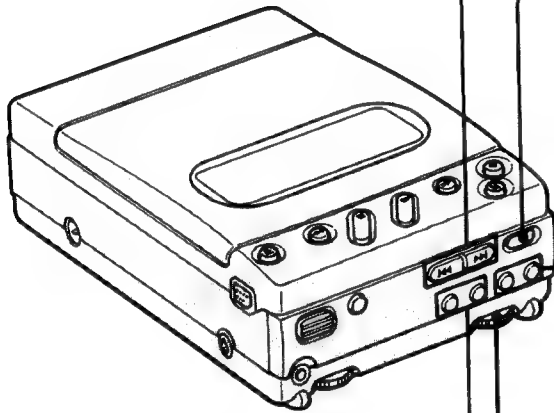

AMS |◀▶▶▶| buttons

Press to locate the beginning of a selection during playback or in the stop mode.

HOLD switch

Set to the right position where you can see the ○ mark to keep the current setting and to avoid accidentally activating the POWER switch, EJECT button and any other operating buttons. COUNTER MODE/RESET and LIGHT buttons work regardless of the position of this switch.

START ID buttons

MODE: The indication on the display window changes to AUTO → (no indication: AUTO off) → ERASE → RENUM each time you press this button. Select the appropriate indication when writing a start ID manually or automatically, eliminating it, or renumbering program numbers.

ENTER: Press to execute when writing a start ID manually, eliminating it, or renumbering program numbers.

REC LEVEL (recording level) control

Adjust the recording level for the analog input signals from MIC/LINE IN jack.

You can control both L (left) and R (right) channel level with this control. When recording digital signals, adjustment of the level is not necessary because it is done automatically.

COUNTER buttons

MODE: Press to select the time display—tape running time, absolute time, elapsed time of the selection, or remaining time.

RESET: Press to reset the counter to 0:00:00s while the tape running time of the selection appears.

Location and Function of Controls

Display window

PGM No. indicator

Shows the number of the selection being played.

REMAIN (remaining time) indicator

Lights when the counter shows the remaining time of the tape.

ABS TIME (absolute time) indicator

Lights when the counter shows the tape running time from the beginning.

PGM TIME (program time) indicator

Lights when the counter shows the elapsed time of the current selection.

During the normal tape counter mode, the above three indicators all go off.

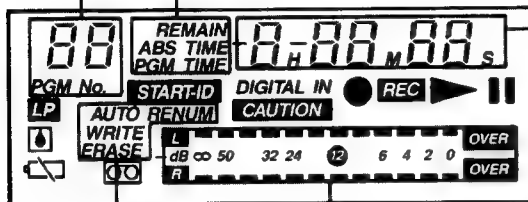

Counter/Indicator for sampling frequency

Displays the linear counter, absolute time, elapsed time of the selection being played, and the total remaining time of the tape. Each time COUNTER MODE is pressed, the display mode changes in turn.

Displays sampling frequency when the ► PLAY button is pressed during playback and recording.

AUTO indicator

Lights when you set to the AUTO mode to write the start ID automatically.

WRITE indicator

Lights when writing the start ID automatically or manually.

ERASE indicator

Lights when erasing the start ID is possible.

RENUM indicator

Lights when renumbering the program numbers is possible.

AUTO, ERASE and RENUM appear in order each time you press START ID MODE. Set the indicator to off to write the start ID manually.

Peak level meters

Indicate peak level of recording or playback signals. In a fast-forward or rewind, ■ mark on the left side meter indicates the direction of the tape running. ■ mark on the right side meter indicates how much tape remains.

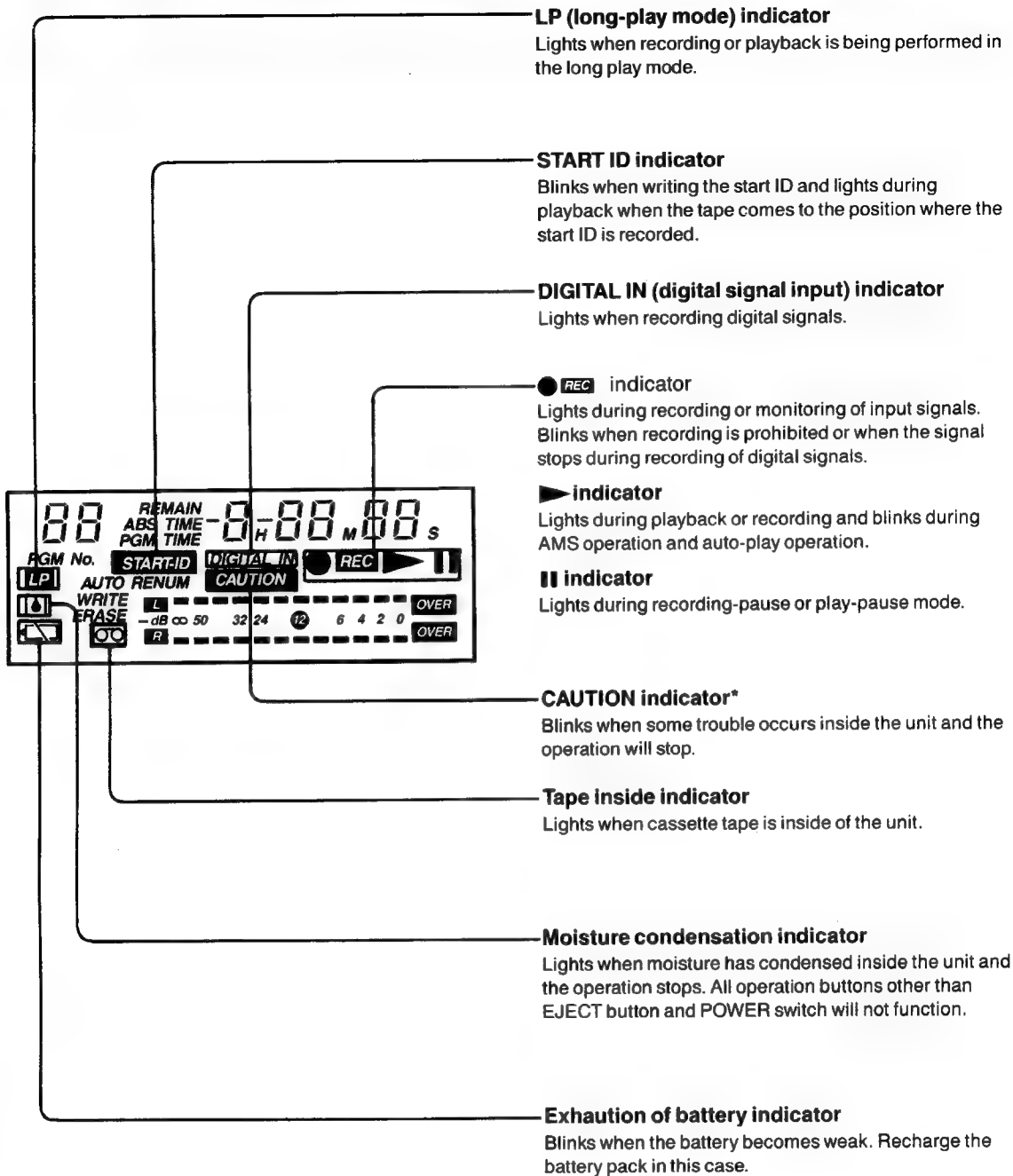

* On the CAUTION indicator
Press the POWER switch again when the CAUTION flickers. If the indicator flickers again or flickers frequently during you use the unit, consult your local Sony's dealer or service station after turning off the power.

Power Sources

Selection of power sources

| Place | Power source |
|------------|----------------------------------------------------------------------------------------------------------------------------------------|
| Outdoors | Rechargeable battery pack (supplied): BP-D3 |
| Indoors | House current AC power adaptor/battery charger (supplied) |
| In the car | 12 V Car battery Car mount arm (equipped with car battery cord, not supplied): CPM-D3 Car battery cord (not supplied): DCC-E190L |

Using with a rechargeable battery pack

Be sure to charge the supplied rechargeable battery pack.

1 First, charge the battery pack.

The charging time is about 1 hour.

① Connect the supplied AC power adaptor to a wall outlet.

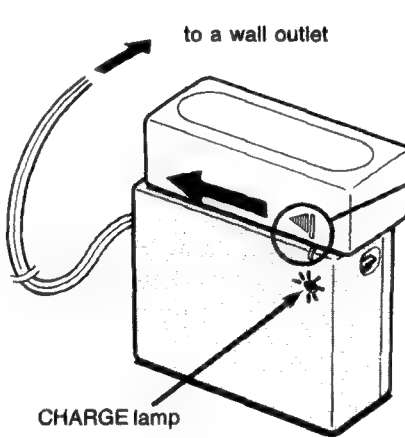

to a wall outlet

② Attach the battery pack to the AC power adaptor. Red CHARGE lamp lights up. Charging is completed when the lamp goes off.

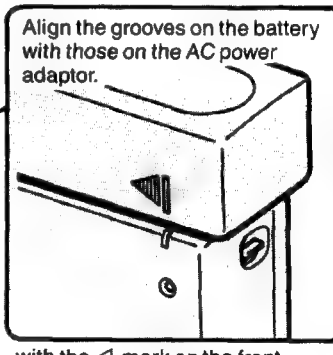

③ Remove the battery pack.

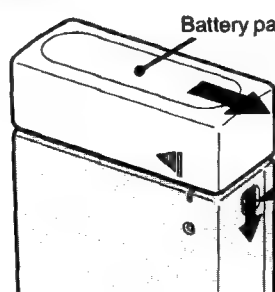

14

2 Attach the battery pack to the unit.

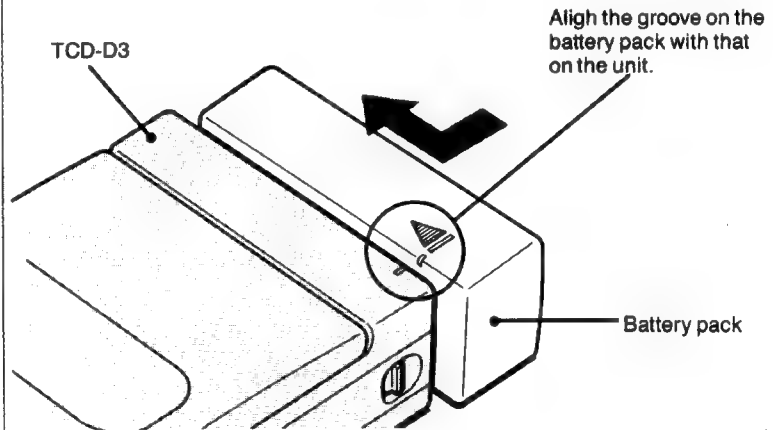

To remove the battery pack from the unit

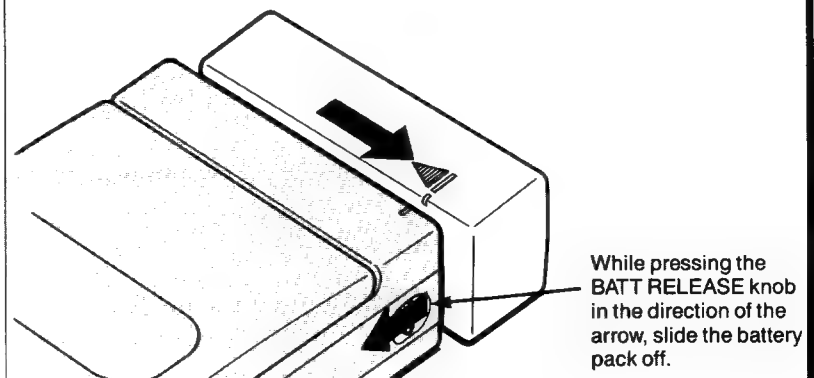



Operating time of the battery pack

A fully-charged battery pack provides approximately 2 hours of continuous use. We recommend that you should prepare more than two battery packs when using DT-120 or recording in the long-recording mode.

If you use the battery pack in a cold place, its operating time is shortened.

When the battery becomes weak

The  indication blinks in the display window. Replace the battery pack with a fully charged one after turning off the power. If you leave the unit with the  indication blinking, the unit will be turned off automatically in 5 minutes.

The battery pack heats up

During charging or recording, the battery pack or the AC power adaptor heats up. This is not dangerous.

Life of the battery pack

When the operating time of the fully-charged battery pack becomes short, purchase a new one and use it.

If you plug in the AC power adaptor to the unit while operating the unit with the battery pack

The unit stops operating automatically.

Note

On treatment

- Keep the metal terminals on the battery pack away from metal objects, otherwise it may short circuit.

On charging

- Charge the battery pack directly before using it.
- Recharge the battery pack only when it is exhausted. (When the  indication begins to blink in the display window, it indicates that the battery pack is exhausted.)
- If you do not use the battery pack for a long time, it becomes fully discharged. A discharged battery cannot be charged to its fully capacity in 1 charge and its operating time becomes short. In this case, recharge 2 or 3 times. (Do not repeat charging except in this case since the battery pack may become damaged.)

How to care for the battery pack

Remove the battery pack from the unit after using it, and keep it in a cool and dry place. When the battery pack is attached to the unit, a small amount of current flows to the unit even if the power is turned off. This may overdischarge and shorten battery life.

Using the AC power adaptor

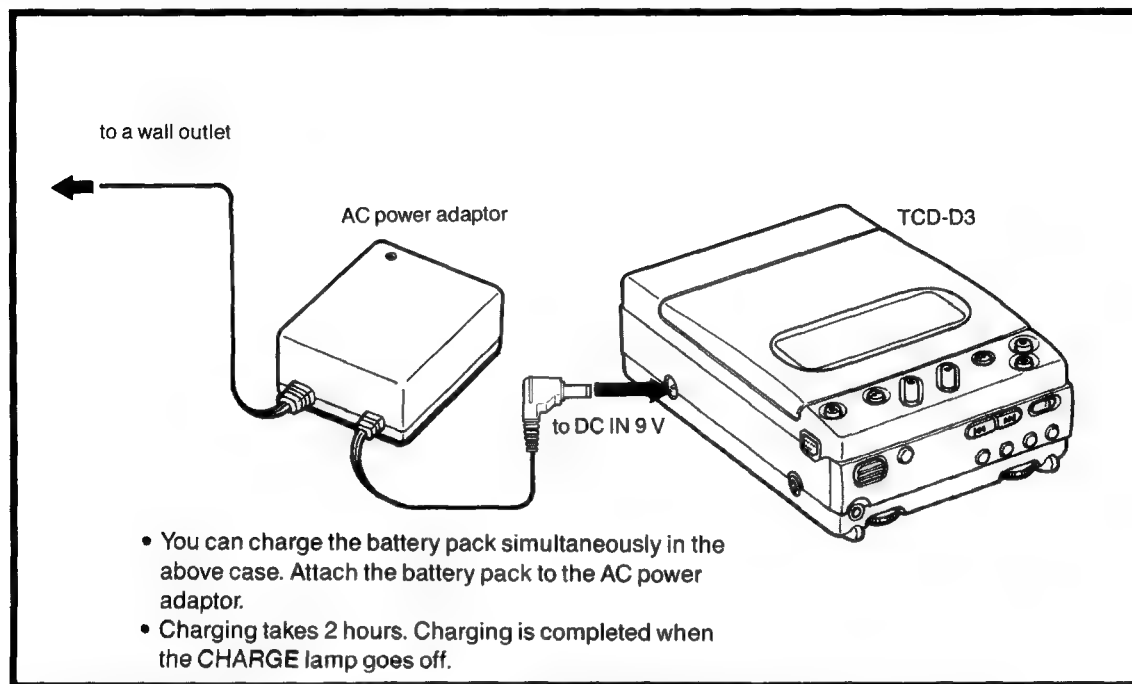

Note on the AC power adaptor

Use only the supplied AC power adaptor.

Never use any other adaptors manufactured by Sony because the polarity of the supplied adaptor is opposite of conventional adaptors.



Polarity of the plug

Notice for customers in Australia

If the supplied cord of this equipment is damaged, it must be replaced by the special cord (KDK type LTSA-2F).

Using the power source in your car

Use the car mount arm equipped with a car battery cord CPM-D3 or the car battery cord DCC-E190L (not supplied).

Note

CPM-D3 cannot be installed a few types of cars. Please consult a Sony dealer in this case.

To Record

Connection with other equipment

Recording via digital output

Adjustment of the recording level is unnecessary because it is done automatically.

When you connect TCD-D3 with other equipment directly

There are 2 ways as follow.

- ① If your equipment has an optical digital output
- ② If your equipment has a coaxial digital output

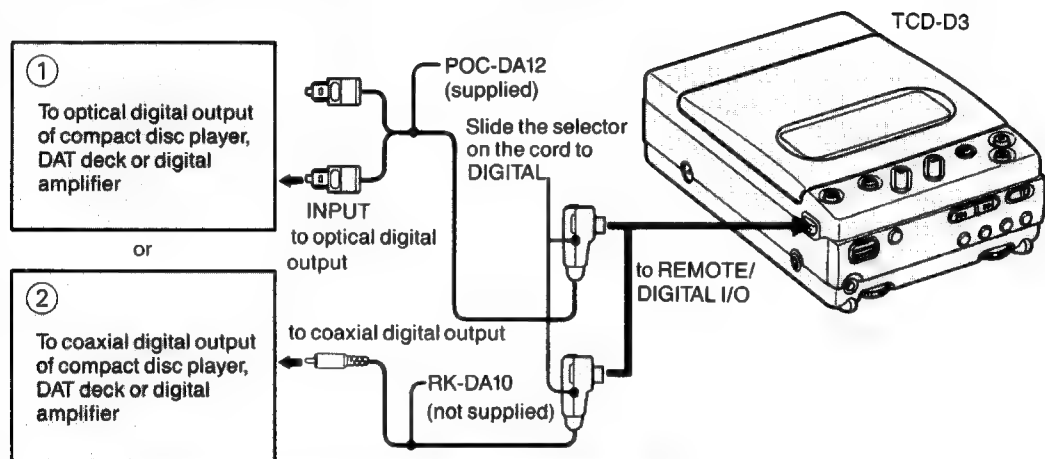

When you connect TCD-D3 with an adaptor kit RM-D3K (not supplied)

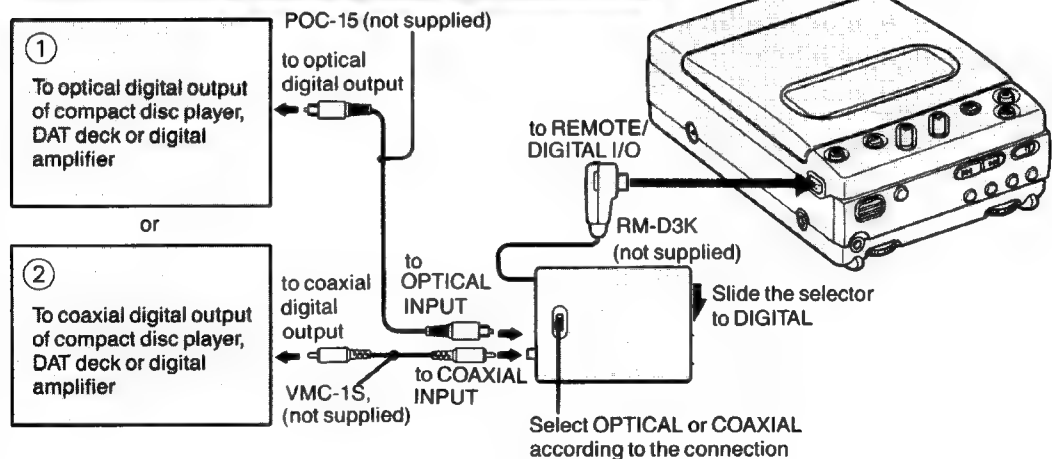

If you connect an RM-D3K (not supplied)

The unit enables recording and playback via digital input/output (optical, coaxial), operation with a wireless remote commander and timer-activated recording or playback with your audio-timer.

If you cannot record via the digital input/output

● **REC** blinks in the window display if a digital signal which cannot be recorded is input to the unit or if the digital signal cannot be input to the unit. Record via the analog input/output in this case.

Recording via analog output

- Slide the selector on the cable or adaptor kit to ANALOG if the connection on page 18 has been done.
- Adjustment of recording level is necessary (See page 18).

When you connect to a stereo system or radio cassette corder through a line output

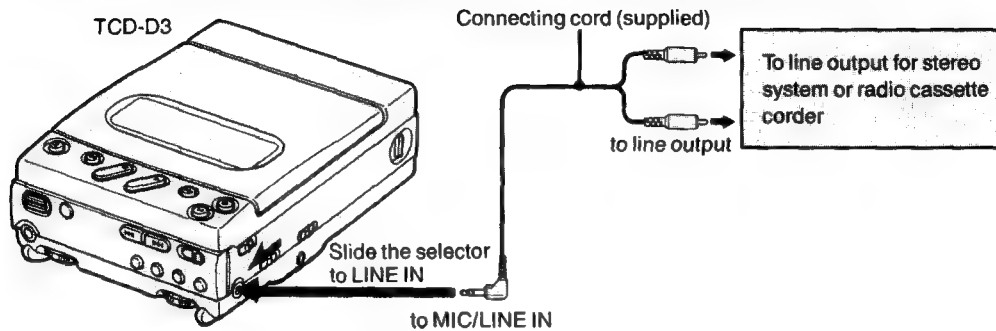

When you connect a microphone

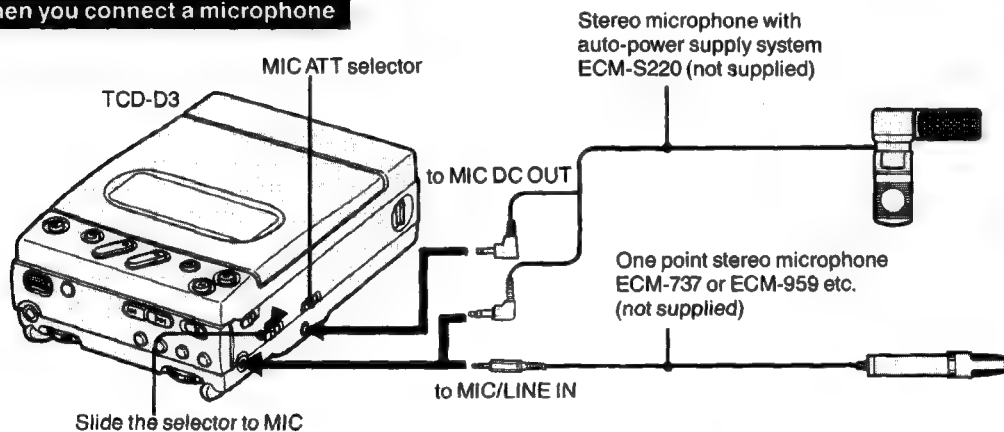

How to use the MIC ATT switch

Set to 0 dB normally. Slide to 20 dB if the level of the input signal is too high causing distortion of the sound.

Monitoring the recorded sound

Connection for playback (See page 18 of "To Play Back") is also necessary.

Note

You cannot use a plug-in power microphone with this unit.

Recording small sounds with a microphone

Digital audio tape-corders enable recording with very little noise. However, if you set the recording level (see page 18) too high and record small sounds with a microphone, noise from the microphone itself or the microphone input amplifier may be magnified and recorded. To reduce noise, set the microphone as close as possible to the sound source and lower the recording level.

The specifications of a microphone also influence recording. We recommend the high-quality microphone ECM-737 or ECM-959 for better recording results.

To Record

Tape insertion

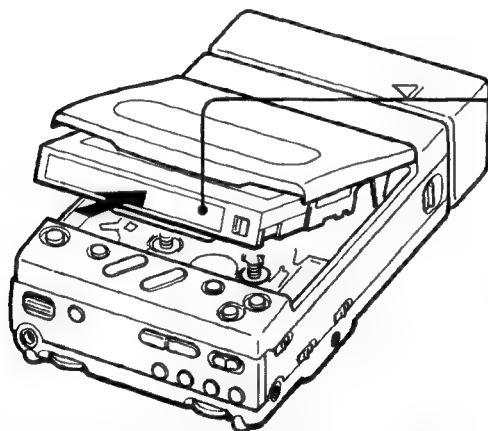
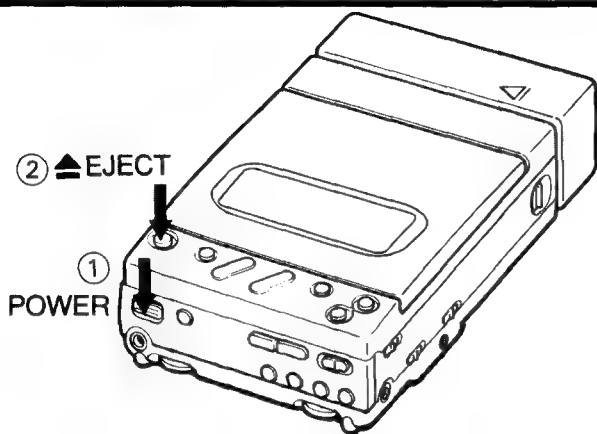

Note

Check if the tape can be recorded with the hole covered before inserting the tape (See page 6).

- Window side up
- Tab facing towards you
- Insert the tape correctly

Insert the tape firmly until it clicks.

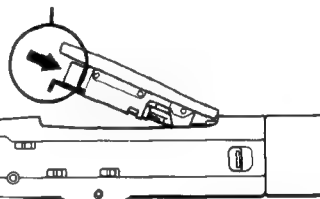

If you close the holder with the tape inserted incorrectly, it may cause the malfunction.

Press the holder closed. Inside the unit, the tape will be loaded around the head automatically. At this time, you can see **LO AD** blinking in the display window.

When detaching the battery pack or the AC power adaptor from the unit, be sure to do it after closing the holder

You may not be able to close the holder if you detach the above power sources just after opening it. In this case, press the POWER switch after attaching the power sources and close the holder.

To remove the tape

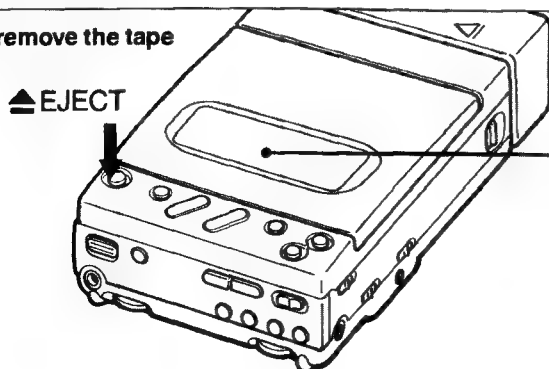

Display window

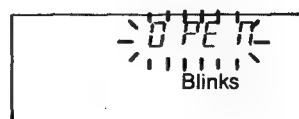

To locate the section to be recorded

| Desired location to be recorded | Condition of your tape | Operation |
|---------------------------------------------------------------------------------------|---------------------------------------------------------------------|-----------------------------------------------------------------------------------------------------------------------------------------------------------------------------------------------------------------------------------------------------------------------------------------------------------------------------|
| From the beginning | New tape | You can begin to record just after setting the tape. You cannot operate any buttons for several seconds while <i>bb 7 oP</i> blinks in the display window. |
| | Wound part way because you had recorded before. | Begin to record after rewinding the tape to the beginning with the REW button. |
| From part way through the tape (from the end of the section you had recorded before). | New tape, but it has been recorded part way and rewound completely. | Forward the tape to the end of the section you have recorded before by pressing the FF button. The tape will stop automatically. |
| | Recorded tape but it has been rerecorded part way. | Locate the boundary between the first section and the second by listening to the sound. Determine the exact boundary by watching the linear counter in the display window. |
| | If you have no idea where you had recorded before. | <ol style="list-style-type: none"> 1 Rewind the tape completely. 2 Press the FF button. The point where the tape stops automatically is the end of the section which you have recorded before. If the tape goes forward to the end of the tape, it indicates that the tape has been fully recorded. |

The above is necessary to avoid making a blank section on your tapes. See "Note on recording" (page 29) for details.

When you use a new tape for the first time *bb 7 oP* appears in the display window. This shows that BB letters are being recorded on the program number in the read-in section. The read-in section enables you to start recording from the beginning of the tape exactly as well as to write and erase the start ID correctly.

To Record

Recording

1 Set the unit before recording.

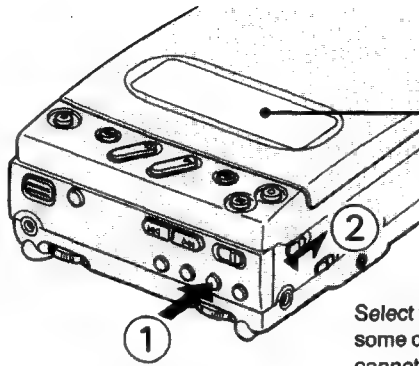

Display window



The indication appears in the long-play mode.

Display AUTO in the window by pressing the START ID MODE button.

Select the recording mode: There are some cases that the long-play mode cannot be used. See page ● for details.
 SP for standard-play mode
 LP for long-play mode

3 If you record via the digital input by connecting the recommended cord or an adaptor kit RM-D3K, slide the switch on the cord or the adaptor kit to DIGITAL. (See page ● when you record via the analog input.)

2 Set to the record-pause mode.

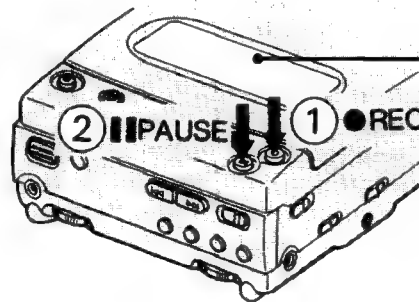

Display window



You can do ② first and then ①.

3 Play your recording source.

4 Release the record-pause mode to start recording.

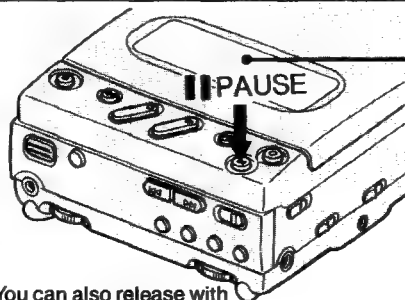

Display window



Blinks (for 9 seconds in the SP mode or 18 seconds in the LP mode). This shows that a start ID* is being written.
 *See page ● about the start ID.

You can also release with the ► PLAY button.

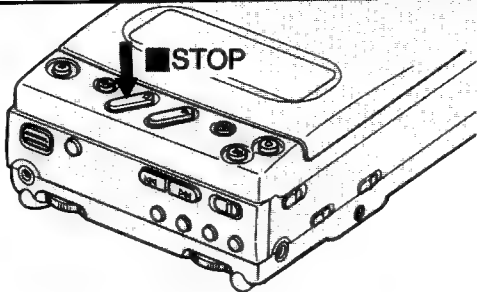
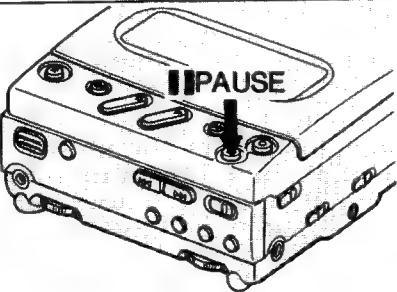
| | |
|----------------------------------------------|------------------------------------------------------------------------------------------------------------------------------------------------------------------------------------|
| <p>To stop recording</p> |  |
| <p>To stop recording for a moment</p> |  <p>Press the PAUSE or ▶ PLAY button to release pause and restart recording.</p> |

If you leave the unit in the record-pause mode for more than 5 minutes
 The record-pause mode will be released automatically and the unit will enter the stop mode. This is because of the protection system for the tape and head. Set to the record-pause mode again if desired.

On operation for recording
 You can record by pressing the PLAY button while you press the ● REC button.

When the tape is recorded to the end (Auto rewind function)
 The tape is rewound to the beginning and stops automatically.

To remove the tape
 Stopping the tape with the STOP button first.

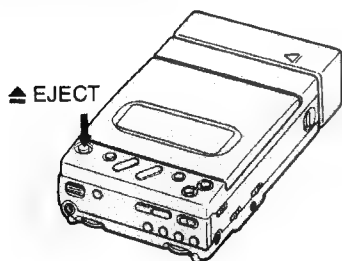

When the input signal is analog
 The following operations are necessary when you record with a microphone or connect a stereo system which does not have digital outputs.

1 Select the appropriate position with the LINE IN/MIC selector.

MIC . . . When you connect a microphone
 LINE . . . When you connect to the LINE OUT jacks of the stereo system

2 Adjust the recording level.

How do you adjust to the appropriate level?
 Adjust the peak level meter to light the indication of the segment around ⊕ (-12 dB) with the REC LEVEL control. The indication does not have to go over 0 dB at the highest level.

If the OVER indication lights continuously
 This shows that the level is too high and will cause sound distortion. Re-adjust to the appropriate level.

3 Start recording.

Recording level when the input signal is digital
 It is unnecessary to adjust the recording level. The digital signal is recorded at the same level as the recording source.

Note on recording

Be sure that no blank section is left on the tape when recording.

Blank section: a portion on which a recording has not been made.

Sound-muted section: a portion on which a recording has been made but with the sound muted.

The following is necessary to avoid leaving a blank section on your tape

Do not advance the tape with the PLAY or FF button. Sound-muted recording can be done to insert silence between selections. Sound-muted recording is done, for example, by recording with the REC LEVEL control at 0 when you record via the analog input or with the REC MUTE button pressed on the adaptor kit RM-D3K (not supplied).

To start recording from the part way through the tape, locate the beginning of the blank section and start recording. This will avoid leaving a blank section.

The reason why you must not leave any blank sections

An absolute time code must be written on the tape correctly. If blank sections are left on the tape, the absolute time code is not recorded there and the tape will stop automatically at each blank section needlessly when you forward the tape or try to locate the beginning of the selection.

What is the absolute time code?

The absolute time indicates the position of the tape, giving the time elapsed from the beginning. The absolute time is recorded automatically at the same time the audio signal is recorded. It cannot be re-recorded. The absolute time allows you to confirm the elapsed time from the start of the tape.

Note

In some cases, the absolute time may not be recorded if you re-record on the tape which the absolute time has not been written.

What is a start ID?

- This signal indicates the start of a music selection. This signal should be written at the beginning of the selection, so that you can locate the position of the start ID precisely.
- If you record with the indication of AUTO in the window, the start ID will be recorded automatically on a tape together with the program number*. We recommend that you record with AUTO in the window. * A program number will not be recorded in some cases. See page 20 for details.

Note

- If you record without the indication of AUTO in the window when recording via analog input, the start ID will not be recorded. But you can record it during playback after recording. (See page 20).
- If you record the sound from an other DAT deck via the digital input without AUTO indicated in the window, the start IDs on the master tape can be recorded. However, when recording the sound from other sources via the digital input, they cannot be recorded.

What is a program number

This signal gives a number to a selection. You can record it where the start ID is written.

On the start ID in the AUTO mode

If there is a no sound section or the signal level stays very low for more than about 3 seconds

A start ID may be written as it is regarded as an interval between two sections.

An unwanted start ID can be erased later. (See page 20)

If the auto space function is available with your CD player, activate this function to ensure that the start IDs are written correctly.

The longest recording period in each time

| Cassette | The longest recording period | |
|----------|------------------------------|-------|
| | standard | long |
| DT-120 | 2h | 4h |
| DT-90 | 1h30m | 3h |
| DT-60 | 1h | 2h |
| DT-46 | 46m | 1h32m |

(h: hour, m: minute)

You can select the appropriate mode—Standard mode (SP) or Long-play mode (LP)—with the mode selector on the unit.

When is the long-recording/playback unavailable?

The digital input signal on 44.1 kHz or 48 kHz cannot be recorded/played back in the long play mode, even if the mode selector is set to LP. Press the ► PLAY button longer than usual during recording to display and check the sampling frequency of the source program in the display window.

The time counter in the long-play mode

Absolute time and total remaining tape appears, based on those in the standard mode. To obtain the actual long play time, double each value.

For the customers who have other DAT decks which do not have the long-play mode

If you playback the tape—which you changed the mode from the standard to the long-play during recording—on other DAT decks which do not have the long-play mode, loud noise may occur at the boundary between the standard mode recorded section and the long-play mode one. Turn down the volume in this case. Same thing occurs when you playback the tape which you made the standard mode recording on which the long-play mode one had been made.

To prevent accidental erasure

When a recording is made, any previously recorded signal will be erased automatically. To prevent accidental erasure, set the safety tab to the position shown in the illustration.

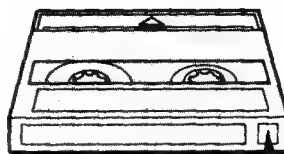

Recording is impossible (with the hole open).



Recording is possible (with the hole covered)

If recording cannot be made

Check the following:

- The safety tab of the cassette is set to the record-inhibit position.
- No tape is loaded.
- The input selector on the unit or the recommended connecting cord, etc., is set to the incorrect position.
- Tape is fully rewound to the end.
- The output level of the playback equipment is too low.
- You are trying to record a signal which cannot be recorded via the digital input. (The ● REC indication blinks in the display window.)

If you repeat recording from the beginning of the tape

The sound which was recorded previously may be heard. This is not a trouble.

To Playback

Connection with other equipment

Connection with other equipment which has a digital input

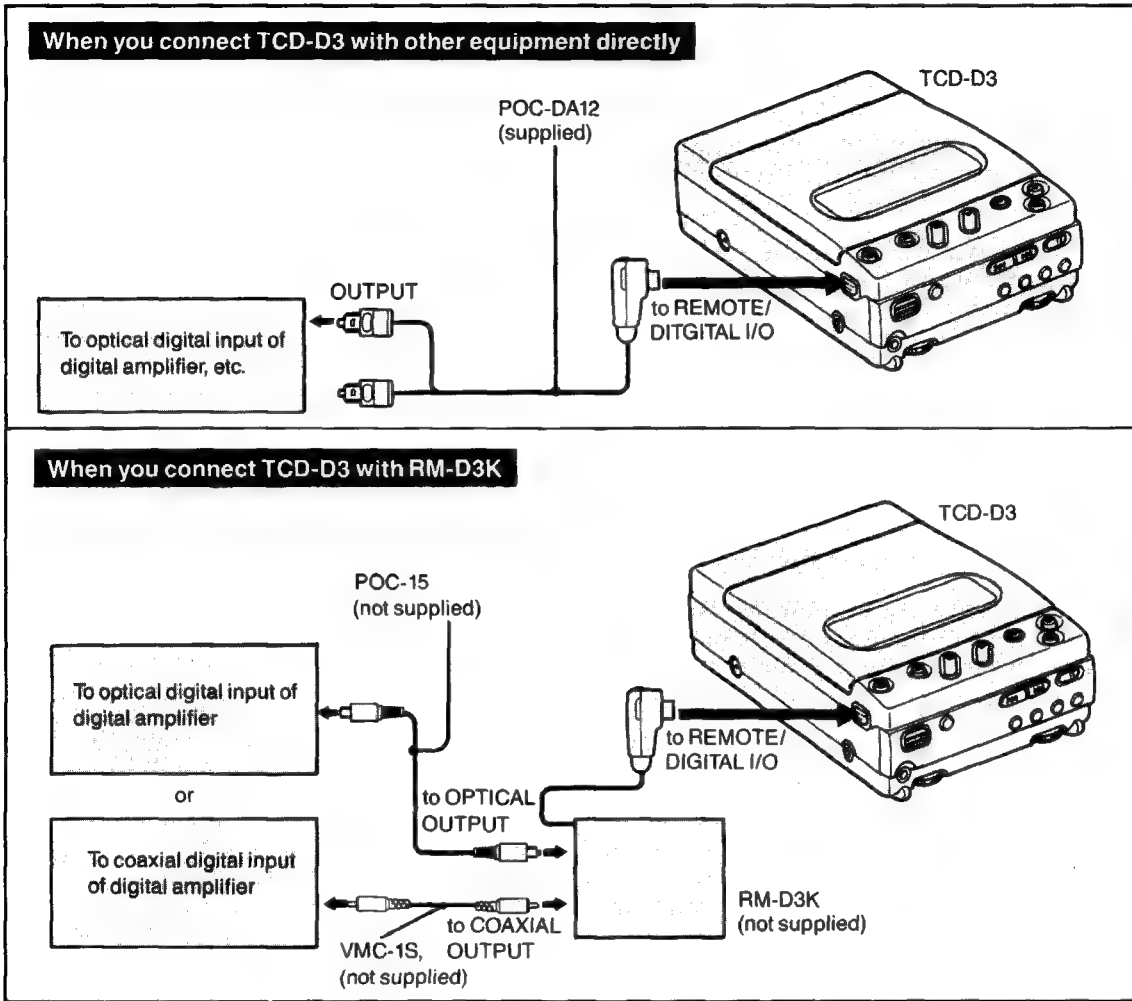

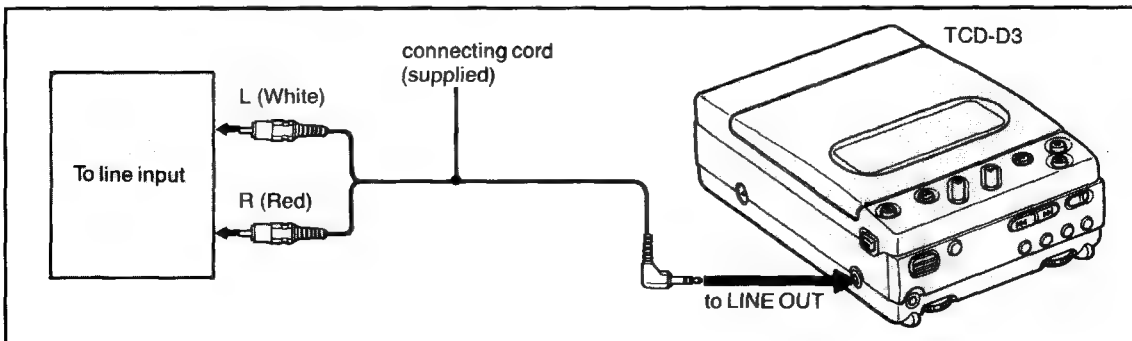

Connection to a stereo system or radio cassette corder through a line input

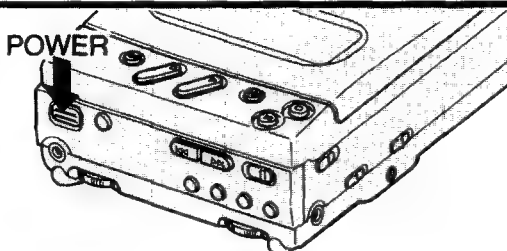
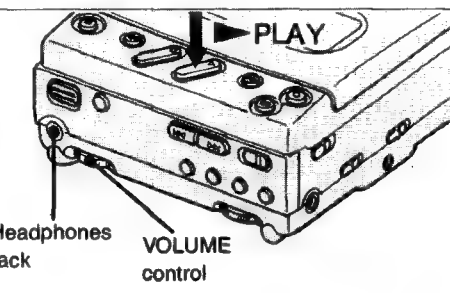

Playback

| | |
|------------------------------------|-----------------------------------------------------------------------------------------------------------------------------------------------------------------------------------------------------------------------------------------------------------------------------------|
| <p>1 Turn the power on.</p> |  |
| <p>2 Insert a tape.</p> | |
| <p>3 Start playback.</p> |  <p>Headphones jack VOLUME control</p> <p>When you use stereo-headphones (stereo-mini plug) Connect it to the headphones jack and adjust the volume with the VOLUME control.</p> |

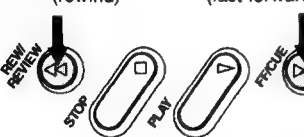
| | |
|----------------------------------------------------------------------------|----------------------------------------------------------------------------------------------------------------------------------------------------------------------|
| <p>To stop playback</p> | <p>■ STOP</p>  |
| <p>To stop playback for a moment</p> | <p> PAUSE</p>  <p>Press the PAUSE or PLAY button to release the pause mode.</p> |
| <p>To fast-forward or rewind the tape First, stop the tape.</p> | <p>◀ REW (rewind) ▶▶ FF (fast-forward)</p>  |

When the tape is played back to its end

The tape will be rewound to the beginning and stop automatically (Auto rewind function)

When you want to rewind the tape and listen to the tape from the beginning

Press the ▶ PLAY button while you press the REW button. ▶ indication in the display window blinks while the tape is rewind. The tape will stop at the beginning of the tape and start playback automatically. (Auto play function)

To fast-forward or rewind the tape while listening to the sound (cue/review)

During playback

◀◀ REVIEW (Listening to the tape while reviewing) ▶▶ CUE (Listening to the tape while advancing)



You can hear the sound while you press the button. Release the button at the desired point. Playback resumes.

A quicker way to fast-forward or rewind

In the cue or review mode, press the ▶ PLAY button while you press the ◀◀ REVIEW or ▶▶ CUE button. You can hear the sound at higher speed than the above.

Note

If there is a more than 9-second blank section on your tape, the tape stops automatically at the beginning of the blank section during playback or fast-forward. Press the operation button again to restart the tape. PGM No. blinks on the program number position in the display window when the tape comes to a blank section.

To Playback

Locating the beginning of the selection—AMS system

For the following operation, start ID codes must be written on the tape. (For how to write the start ID, see page 29.)

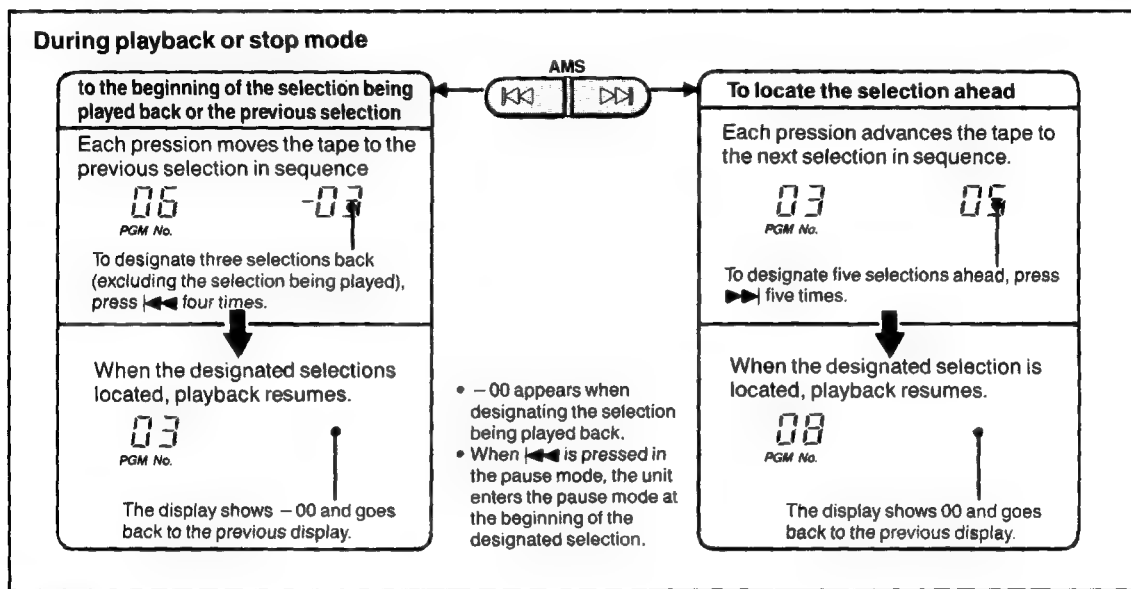

Note

This may not function when you play back the tape which was recorded with other DAT decks.

Using the display window

Each time you press the COUNTER MODE button, the counter changes as follows:

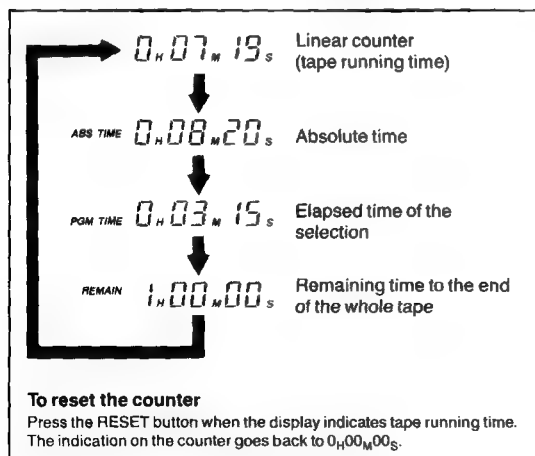

Accuracy of the indicator for the remaining time

Depending on the kind of tape, the indicated time may differ slightly from the actual remaining time.

On the indicator for the elapsed time of the selection

The indicator does not appear in the following cases.

- The selection is played back from the middle.
- The tape is being fast-forwarded or rewind.

On the indicator for the remaining time

- The indicator does not appear immediately after the deck is set to the playback mode. It will appear about 16 seconds later.
- Depending on the kind of tape, the indicator may differ slightly from the actual remaining time.

To check the recorded sampling frequency

Press the ▶ PLAY button longer than usual during playback. The sampling frequency will appear in the display window as long as you press the button.

Display window

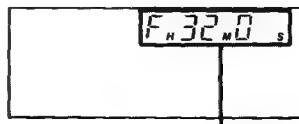

(example: 32 kHz sampling frequency is recorded.)

Nice to Know

On start ID

You can write the start ID manually

Usually, the start ID is automatically recorded in the AUTO mode. You can also write it manually by yourself.

For example, write it manually in the following cases:

- If you forgot to set the AUTO mode when recording so you get a tape on which the start ID is not recorded.
- If you want to record the start ID in middle of a selection to locate a particular portion.

Start ID is a convenience for you to locate the beginning of the selection and to edit the tape.

Note

Be sure to check that the safety tab on the tape covers the hole before operating.

Writing start ID manually during recording

| | Operation | Result |
|---|----------------------------------------------------------------|----------------------------------------------------------------------------------------------------------------------------------------------------|
| 1 | Press START ID MODE for a few times. | AUTO or no indication appears in the window. |
| 2 | Press START ID ENTER at the desired position during recording. | WRITE lights and START ID blinks in the display window. (9 seconds for standard mode, 18 seconds for long play mode.) Writing is completed. |

Writing start ID manually during playback

| | Operation | Result |
|---|----------------------------------------------------------------|-------------------------------------------------------------------------------------------------------------------------------------------------------------------------------------------------------------------------------------------------------|
| 1 | Press START ID MODE for a few times. | AUTO or no indication appears in the window. |
| 2 | Press START ID ENTER at the desired position during playback. | WRITE and START ID blink in the display window, and a 3-second portion from the point where you press START ID ENTER, is played back repeatedly (rehearsal function). The beginning of the repeated portion will be beginning of the start ID. |
| 3 | Press START ID ENTER again if the position is the desired one. | WRITE lights and START ID blinks while the start ID is written. You cannot hear the sound at this time. |

Adjust the position if there is a gap between the position where the start ID is written and the desired one. (See page ●.)

Nice to Know

How to adjust the start ID position

You can shift the start ID position about 0.3 seconds backward or forward with REW/REVIEW or FF/CUE during rehearsal play. Press ENTER after shifting it to the desired position. The start ID cannot be shifted except in the rehearsal mode.

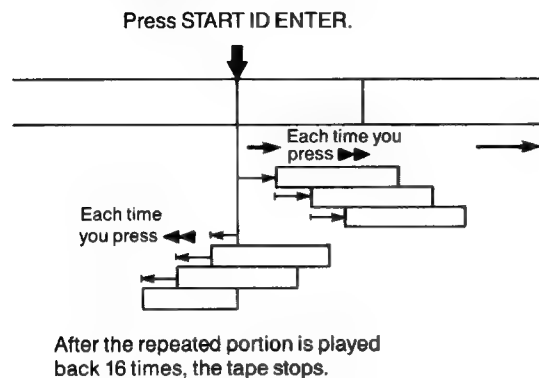

Note

- You must adjust the position within ten seconds.
- You cannot activate any operation buttons other than ■ STOP while the start ID is being written.
- When WRITE and **START ID** blink quickly during rehearsal play, the start ID cannot be written.
- The program number cannot be written when the start ID is written during playback.

Erasing start ID

Locate the tape at beginning of the desired start ID to be erased. You can erase it during playback or stop mode.

| | Operation | Result |
|---|------------------------------------------------------------------------|-------------------------------------------------------------------------------------------------------------------------------------------------------------------------------------------------------------------------------------------|
| 1 | Locate the tape at the beginning of the desired start ID to be erased. | |
| 2 | Press START ID MODE a few times. | ERASE appears in the display window. |
| 3 | Press ENTER during playback or stop mode. | <p>The tape is rewound and the start ID is searched for. ERASE blinks during this time.</p> <p>↓</p> <p>The start ID is erased after being detected. ERASE lights and START ID blinks at this time. You cannot hear the sound.</p> |

Note

The program number is erased at the same time you erase the start ID.

On program number

If AUTO appears in the display window when recording from the beginning of the tape, the program number is automatically written together with start ID. Renumber it in the following cases because it may not be written or it may overlap.

- The succeeding program numbers are not written because you started recording from the middle of the tape.
- The same program number may be written twice on the tape because you have recorded from the beginning to the middle of a tape on which another recording was made.
- When you write a start ID during playback.
- If you erase the start ID, the program number will be automatically erased. This means that there may be some missing numbers on the tape.

Unless you renumber the program numbers, it may be inconvenient for you because the same program number may appear twice or you cannot select the desired selection with the numeric button on the adaptor kit RM-D3K (not supplied).

Note

This may not function when you write or renumber the program numbers on the tape which was recorded with other DAT decks.

Renumbering program numbers

Be sure to check that the safety tab on the tape covers the hole before operating.

| | Operation | Result |
|---|-------------------------------------------|----------------------------------------------------------------------------------------------------------------------------------------------------------------------------------------------------------------------------------------------------------------------------------------------------------------------------------------------------------------------------------------------------------------------------------------------------------------------------------------------------------------------------------------------------------------------------------------------------------------------------------------------------------------------|
| 1 | Press START ID MODE a few times. | RENUM appears in the display window. |
| 2 | Press ENTER during playback or stop mode. | <ul style="list-style-type: none">• The tape will automatically be rewound to the beginning, and the program numbers are renumbered from "1" in order at each start ID position.• At that time, you can hear the beginning of the section for 3 seconds. The tape will be rewound to the beginning again and the number will be written without sound. The unit will repeat at each section.• START ID blinks while the program numbers are renumbered. RENUM blinks while the tape is fast-forwarded to the next start ID.• If the pre-recorded program number is correct, the unit searches for the next start ID. |

When renumbering is completed

The tape is automatically rewound to the beginning, and the function of the unit stops.

Erasing program number

Refer to "Erasing start ID". The program number will be erased together with the start ID.

How to Use the Carrying Case

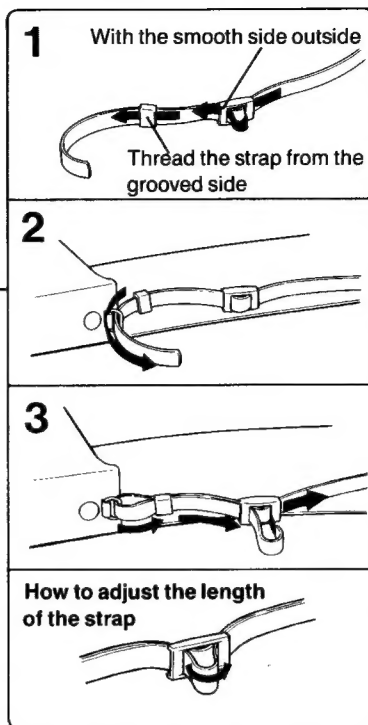
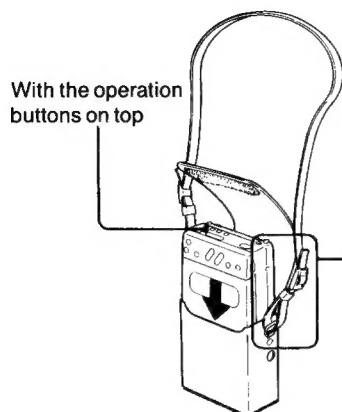

Maintenance

Cleaning the Cabinet

Clean the cabinet, panels, and controls with a soft cloth slightly moistened with a mild detergent solution. Do not use any type of abrasive pad, scouring powder or solvent such as alcohol or benzine.

Cleaning the Head

Prolonged operation will cause contamination of the head. To make the best possible recording and playback, we recommend cleaning the head periodically, using the DT-10CL cleaning cassette (not supplied).

How to use the cleaning cassette

- 1 Insert the cleaning cassette as you would a normal DAT cassette.
- 2 Press ►. Press ■ after about 10 seconds.
- 3 Remove the cleaning cassette without rewinding it.
- 4 Proceed with recording and playback with a normal DAT cassette and check the sound quality.

Notes on the cleaning cassette

- The cleaning cassette cannot be used for recording and playback.
- Do not clean the head with the cleaning cassette more than five times over a short period. Cleaning the head continuously for too long a period of time may cause wear to the head.
- Do not rewind the cleaning cassette each time you use it. When the cleaning cassette tape is taken up completely, rewind it to the beginning and re-use it. The cleaning cassette can be used a hundred times, with 10 seconds of cleaning each time. The DT-10CL cleaning cassette is available.

Specifications

| | |
|------------------|--------------------------------------------------------------------------------------|
| Tape | Digital audio tape |
| Recording head | Rotary head |
| Recording time | Standard: 120 minutes Long-play mode: 240 minutes (with DT-120) |
| Tape speed | Standard: 8.15 mm/s Long-play mode: 4.075 mm/s |
| Drum rotation | Standard: 2,000 rpm Long-play mode: 1,000 rpm (record) 2,000 rpm (playback) |
| Error correction | Double Read Solomon code |

Tape

| | |
|---------------------------|-------------------------------------------------------------------------------------------------------------------------------------------------------------------------------------------------------------------------|
| Track pitch | 13.6 μ m (20.4 μ m) |
| Sampling frequency | 48 kHz, 44.1 kHz, 32 kHz |
| Modulation system | 8-10 Modulation |
| Transfer rate | 2.46 Mbit/sec. |
| Number of channel | 2 channels, stereo |
| Quantization | Standard: 16-bit linear Long-play mode: 12-bit Non linear |
| Frequency response | Standard: Fs 48 kHz 20 ~ 22,000 Hz (± 1.0 dB) Fs 44.1 kHz 20 ~ 20,000 Hz (± 1.0 dB) Fs 32 kHz 20 ~ 14,500 Hz (± 1.0 dB) Long-play mode: Fs 32 kHz 20 ~ 14,500 Hz (± 1.0 dB) |
| Signal to noise ratio | Standard: more than 90 dB Long-play mode: more than 90 dB (1 kHz IHF-A, 22 kHz LPF, LINE IN) |
| Dynamic range | Standard: more than 90 dB Long-play mode: more than 90 dB (1 kHz IHF-A, 22 kHz LPF, LINE IN) |
| Total harmonic distortion | Standard: less than 0.008% (1 kHz, 22 kHz LPF, LINE IN) Long-play mode: less than 0.09% (1 kHz, 22 kHz LPF, LINE IN) |
| Wow and flutter | Below measurable limit (less than $\pm 0.001\%$ W, PEAK) |

Input

| | Jack type | Impedance | Rated input level | Minimum input level |
|-----------------|---------------------|--------------------------------------------|-------------------|--------------------------------------|
| MIC/ LINE IN | stereo mini jack | MIC IN 4.7 kohms LINE IN 47 kohms | LINE IN 500 mV | MIC IN 0.4 mV LINE IN 80 mV |

Output

| | Jack type | Impedance | Rated output | Maximum output level | Load impedance |
|-------------|---------------------|-----------|--------------|----------------------|-----------------------|
| LINE OUT | stereo mini jack | 700 ohms | 500 mV | — | More than 10 kohms |
| PHONES | stereo mini jack | 27 ohms | — | 17 mW + 17 mW | 32 ohms |

Input/Output

REMOTE, DIGITAL I/O jack (special jack)
Digital input/output, remote control operation and timer-activated operation is possible by connection with an adaptor kit to this jack.

Other jack

MIC DC OUT (special mini jack)

General

Power requirements DC 6 V When mounting battery
DC IN 9 V jack
When using AC power adaptor (supplied):

| Where purchased | Operating voltage |
|-----------------|-------------------|
| United States | 120 V AC, 60 Hz |
| United Kingdom | 240 V AC, 50 Hz |
| Australia | 240 V AC, 50 Hz |

Car battery cord (CPM-D3 or DCC-E190L)
for 12 V car

Battery life Approx. 2 hours (Consecutive recording or playback with full-charged BP-D3 when turning off the illumination for display window)

Power consumption 3.6 W

Dimensions Approx. 85.2 x 40 x 120.1 mm
(3 $\frac{3}{8}$ x 1 $\frac{5}{8}$ x 4 $\frac{3}{4}$ in.)
(w/h/d) not incl. the battery pack incl. projecting parts and controls

Approx. 85.2 x 40 x 145.9 mm
(3 $\frac{3}{8}$ x 1 $\frac{5}{8}$ x 5 $\frac{3}{4}$ in.)
(w/h/d) incl. the battery pack and projecting parts and controls

Weight Approx. 420 g (15 oz)
not incl. battery pack
Approx. 630 g (1 lb 6.3 oz)
incl. battery pack

Supplied accessories

AC power adaptor/battery charger (1)
ACP-D3U (United States)
ACP-D30 (United Kingdom and Australia)
Rechargeable battery BP-D3 (1)
Carrying case (1)
Digital cable (special plug—2 optical plugs) POC-DA12 (1)
Audio connecting cords (2) (stereo-mini plug—2 phono plugs,
stereo for line inputs and outputs)
DAT tape DT-60 (1)

Design and specifications subject to change without notice.

Accessories not supplied

System adaptor kit RM-D3K
Digital cable (special plug—phono plug) RK-DA10
Car mount arm CPM-D3 (Car battery cord included)
Car battery cord DCC-E190L
System carrying case LCH-D3
Rechargeable battery BP-D3
One-point stereo microphone ECM-S220, ECM-737, ECM-959
Stereo earphones MDR-E575
Active speaker SRS-58
Cleaning cassette DT-10CL

Your dealer may not handle some of the above listed accessories. Please ask the dealer for detailed information about the accessories.

Troubleshooting Guide

| | Symptom | Cause | Remedy |
|--------------------------------------------------------|------------------------------------------------------------------------------------------|----------------------------------------------------------------------------------------|--------------------------------------------------------------------------------------------------------------------------------------------------------------------------------------------------------------------------------------------------------------------------------------------------------------------------------------------------------------------------------------------------------------------------------------------------------------------|
| Basic operation | Operation buttons cannot be pressed. The unit does not work. | HOLD switch is slid to the right side. | Slide the switch to the left side. |
| | | The battery pack is exhausted. | Charge the battery pack. |
| | | The power source is connected incorrectly. | Connect correctly. |
| | The tape does not move. | The PAUSE button is activated. (The II indicator lights in the display window.) | Press PAUSE or PLAY to release pause. |
| | | The tape is wound completely. | Press ◀◀ or ▶▶ button to rewind. |
| | Sound is not heard. | The volume control is set to the minimum position. | Adjust the control correctly. |
| | | Incorrect operation of the connected amplifier. | Operate the amplifier as required by the unit operation. (Refer to the operating instructions of the amplifier.) |
| | | The head may be contaminated. | Clean the head with the cleaning cassette. |
| | Recording cannot be made. | The safety tab of the cassette is open. | Close the tab of the cassette. |
| | | Incorrect position of the input selector. | Set to the correct one. When recording the signal from REMOTE DIGITAL I/O jack: Set the selector on the connecting cable or an adaptor kit to DIGITAL. When recording the signal from LINE IN/MIC jack: Set the selector on the connecting cord or adaptor kit to ANALOG. When recording the signal from the line output: Set the LINE IN/MIC selector to LINE IN. When recording the signal from the microphone: Set the LINE IN/MIC selector to MIC. |
| | Recording cannot be made with the ● REC indicator blinking in the display window. | A signal which cannot be recorded as a digital signal is input to the unit. | Input the signal via analog input jack. |
| | Sound is not recorded on the tape. | Recording level control is set to the minimum when recording via the analog input. | Adjust the control correctly. |
| The ☐ mark blinks and operation cannot be done. | The safety system is activated due to moisture condensation. | After leaving the unit as it is for a while, restart the unit by turning on the power. | |

| Symptom | Cause | Remedy |
|---------------------------------------------------------------------|--------------------------------------------------------------------------------------------------------------------------------------------------------|------------------------------------------------------------------------------------------------------------------------------------------------------------------------------------------------------------------|
| Neither start ID nor program number can be written. | The safety tab on the cassette is open. | Close the tab of the cassette. |
| Search function does not activate during playback. | The start ID is written but it is less than 9 seconds long (less than 18 seconds in the long play mode.) | Erase the start ID and rewrite it. (See page 34.) |
| | The portion between the end of a start ID and the beginning of the following start ID is less than 18 seconds (36 seconds in the long play mode) long. | When writing the start IDs manually, be sure to have an intervals of more than 18 seconds (36 seconds in the long-play mode) between IDs. |
| Operation buttons do not work while the start ID is written. | While writing the start ID (9 seconds or 18 seconds), none of the buttons except STOP button can be used. | Press them after the start ID is written. |
| Absolute time cannot be written. | Recording was started from a blank section. | Rewind the tape to the beginning, locate the very last point of the previous recording and start recording from that point. |
| The sound from the microphone is distorted. | The volume of the sound source is too high. | Set the MIC ATT switch to 20 dB. |
| Noise occurs during recording. | When monitoring the recording sound with headphones or external speakers, they are too close to a microphone. | Keep a microphone away from them or decrease the volume of monitored sound. |
| The operating time of the fully-charged battery pack is short. | The battery pack cannot be fully charged since it has not been used for a long time. | Recharge 2 or 3 time. (Do not repeat charging except in this case since the battery pack may become damaged.) |
| | The life of the battery pack comes to an end. | Replace with a new one. |
| | You charged the battery pack and/or used the unit in a cold place. | The operating time gets shorter in a cold place. |
| The tape stops suddenly during tape running. | There is a blank section which is more than 9 seconds long. | |
| Increase of noise or deterioration of sound. | Contamination of the head. | Clean the head, using the cleaning tape. |
| The CAUTION indicator blinks and no buttons do not function. | Something abnormal has occurred inside the unit. | Turn off the power and turn it on again. If the CAUTION indicator blinks again or blinks frequently during you use the unit, turn off the power and consult your nearest store or Sony's service station. |
| You cannot close the holder. | You detach power sources from the unit just after opening the holder. | Press the POWER switch after attaching the power sources and close the door. (See page 34.) |

Other ManualsLib Projects



www.manualslib.com



www.manualslib.de



www.manualslib.es



www.manualslib.fr



www.manualslib.nl



www.manualslib.mx



www.manualslib.tech 30+ Languages