

TCD-D3

SERVICE MANUAL



*US Model
Canadian Model
AEP Model
UK Model
E Model
Australian Model*

DAT
Digital Audio Tape

SPECIFICATIONS

Tape	Digital audio tape
Recording head	Rotary head
Recording time	Standard: 120 minutes Long-play mode: 240 minutes (with DT-120)
Tape speed	Standard: 8.15 mm/s Long-play mode: 4.075 mm/s
Drum rotation	Standard: 2,000 rpm Long-play mode: 1,000 rpm (record) 2,000 rpm (playback)
Error correction	Double Read Solomon code
Tape	
Track pitch	13.6 μ m (20.4 μ m)
Sampling frequency	48 kHz, 44.1 kHz, 32 kHz
Modulation system	8-10 Modulation
Transfer rate	2.46 Mbit/sec.
Number of channel	2 channels, stereo
Quantization	Standard: 16-bit linear Long-play mode: 12-bit Non linear
Frequency response	Standard: Fs 48 kHz 20 ~ 22,000 Hz (\pm 1.0 dB) Fs 44.1 kHz 20 ~ 20,000 Hz (\pm 1.0 dB) Fs 32 kHz 20 ~ 14,500 Hz (\pm 1.0 dB) Long-play mode: Fs 32 kHz 20 ~ 14,500 Hz (\pm 1.0 dB)
Signal to noise ratio	Standard: more than 90 dB Long-play mode: more than 90 dB (1 kHz IHF-A, 22 kHz LPF, LINE IN)
Dynamic range	Standard: more than 90 dB Long-play mode: more than 90 dB (1 kHz IHF-A, 22 kHz LPF, LINE IN)
Total harmonic distortion	Standard: less than 0.008% (1 kHz, 22 kHz LPF, LINE IN) Long-play mode: less than 0.09% (1 kHz, 22 kHz LPF, LINE IN)
Wow and flutter	Below measurable limit (less than \pm 0.001% W.PEAK)

Input

	Jack type	Impedance	Rated input level	Minimum input level
MIC/ LINE IN	stereo mini jack	MIC IN 10 kohms LINE IN 47 kohms	LINE IN 500 mV	MIC IN 0.25 mV LINE IN 80 mV

Output

	Jack type	Impedance	Rated output	Maximum output level	Load impedance
LINE OUT	stereo mini jack	700 ohms	500 mV	—	More than 10 kohms
HEAD- PHONES	stereo mini jack	27 ohms	—	17 mW + 17 mW	32 ohms

Input/Output

REMOTE, DIGITAL I/O jack (special jack)

Digital input/output, remote control operation and timer-activated operation is possible by connection with an adaptor kit to this jack.

Other jack

MIC DC OUT (special mini jack)

General

Power requirements	DC 6 V When mounting battery DC IN 9 V jack When using AC power adaptor (supplied): AC 120 V, 60 Hz (US, Canadian model) : AC 220 V, 50 Hz (AEP model) : AC 240 V, 50 Hz (UK model) : AC 100-240 V, 50/60 Hz (E model) : AC 240 V, 50 Hz (Australian model) : AC 120-240 V, 50/60 Hz (Saudi Arabia model) Car battery cord (CPM-D3) for 12 V car
--------------------	---

—continued on next page—

DIGITAL AUDIO TAPE-CORDER
SONY®

Battery life	Approx. 2 hours (Consecutive recording or playback with full-charged BP-D3 when turning off the illumination for display window)
Power consumption	3.6 W
Dimensions	Approx. 85.2 × 40 × 120.1 mm (3 $\frac{3}{8}$ × 1 $\frac{5}{8}$ × 4 $\frac{3}{4}$ in.) (w/h/d) not incl. the battery pack incl. projecting parts and controls Approx. 85.2 × 40 × 145.9 mm (3 $\frac{3}{8}$ × 1 $\frac{5}{8}$ × 5 $\frac{3}{4}$ in.) (w/h/d) incl. the battery pack and projecting parts and controls
Weight	Approx. 420 g (15 oz) not incl. battery pack Approx. 630 g (1 lb 6.3 oz) incl. battery pack

Supplied accessories

- AC power adaptor/battery charger ACP-D3U (1) (US, Canadian Model)
- AC power adaptor/battery charger ACP-D30 (1) (AEP, UK, Australian model)
- AC power adaptor/battery charger ACP-D33 (1) (E model)
- AC power adaptor/battery charger ACP-D33 (1) (Saudi Arabia model)
- Adaptor conversion 2P (1) (E model)
- Rechargeable battery BP-D3 (1)
- Carrying case (1)
- Digital cable (special plug—2 optical plugs) POC-DA12 (1)
- Audio connecting cords (2) (stereo-mini plug—2 phono plugs, stereo for line inputs and outputs)
- DAT tape DT-60 (1)

Design and specifications subject to change without notice.

NOTE ON THE AC POWER ADAPTOR

Use only the supplied AC power adaptor.
Never use any other adaptors manufactured by Sony because the polarity of the supplied adaptor is opposite of conventional adaptors.



Polarity of the plug

FEATURES

Application of the serial copy management system

This unit utilizes a serial copy management system which permits digital-to-digital recording for one generation. You can record CD sound or other digital formats through a digital-to-digital connection.

Three sampling frequencies

Recording/playback can be done with three sampling frequencies 48 kHz, 44.1 kHz and 32 kHz.

48 kHz: For analog input signals in a standard mode and 48 kHz, digital audio signals.

44.1 kHz: For digital input of compact disc and pre-recorded DAT tape.

32 kHz: For analog input signals in a long-play mode and 32 kHz digital audio signals.

Capability for recording an analog signal source

MIC/LINE IN jack on the unit in addition to digital input/output allows recording of an analog signal source from a microphone or line output signal from stereo speaker.

Excellent sound quality

Excellent sound quality through a built-in over sampling digital filter.

Miniaturized digital audio tape recorder

The newly-developed miniaturized mechanism and ICs make possible this very small digital audio tape recorder.

Long play mode

This unit can operate in a long play mode. Analog input signals or 32 kHz digital signals can be recorded or played back for up to four consecutive hours when the DT-120 DAT cassette tape is used. The sampling frequency will be 32 kHz in the long play mode.

Post edit recording of start ID and program numbers

You can record or rewrite the start ID and program numbers after the audio signal recording has been completed.

Locating the beginning of the selection at high speed.

Liquid crystal display with a back-light system.

Approximately two-hour continuous recording and playing is possible with the supplied rechargeable battery.

AC power adaptor which can be used during charging is supplied.

TABLE OF CONTENTS

<u>Section</u>	<u>Title</u>	<u>Page</u>	<u>Section</u>	<u>Title</u>	<u>Page</u>
1. SERVICE NOTES			4-3. ELECTRICAL ADJUSTMENTS		
1-1.	How to Open the Holder (upper) Assy	4	4-3-1.	SWP (Switching Pulse) Adjustment	27
1-2.	How to Connection of Translation Flexible Boards	4	5. DIAGRAMS		
2. GENERAL			5-1.	Circuit Boards Location	28
•	Guide to the Serial Copy Management System	5	5-2.	Semiconductor Lead Layouts	28
•	Location and Function of Controls	6	5-3.	Block Diagram	29
•	Power Sources	9	5-4.	Printed Wiring Boards	
•	To Record	10	—	System Control/Servo Section	33
•	To Playback	14	5-5.	Schematic Diagram	
•	Nice to Know	15	—	System Control/Servo Section	37
3. DISASSEMBLY			5-6.	Schematic Diagram	
3-1.	Lower Panel Assy	17	—	Audio/Display Section	41
3-2.	Main Board	17	5-7.	Printed Wiring Boards	
3-3.	Cassette Lid Assy	18	—	Audio/Display Section	45
3-4.	Cabinet (upper) Assy	18	5-8.	Pin Description	51
3-5.	Control Panel Assy	18	6. EXPLODED VIEWS		
3-6.	Chassis	19	6-1.	Cabinet Assembly	59
3-7.	LCD Assy	19	6-2.	Chassis Assembly	60
3-8.	Drum Assy	19	6-3.	Cassette Holder Assembly	61
4-1. ADJUSTMENTS			6-4.	MD Assembly 1	62
4-1-1.	Note for the Adjustments	20	6-5.	MD Assembly 2	63
4-1-2.	Test Mode	20	7. ELECTRICAL PARTS LIST		64
4-1-3.	Adjustments Parts Position	24	SUPPLEMENT-1		71
4-2. MECHANICAL ADJUSTMENTS					
4-2-1.	Tape Pass Adjustment	24			
4-2-2.	End Sensor Check	26			
4-2-3.	Torque Check	26			
4-2-4.	Speed Check	26			

SECTION 1 SERVICE NOTES

1-1. HOW TO OPEN THE HOLDER (UPPER) ASSY

1. In case of setting state
At the beginning remove the LCD assy, and slide in the direction of arrow ① to lever of an oblique line by slender screw driver , etc. from hole A of holder (upper) assy.
2. In case of MD block
Slide was be hooked claw for tension spring slide in the direction of arrow ②.

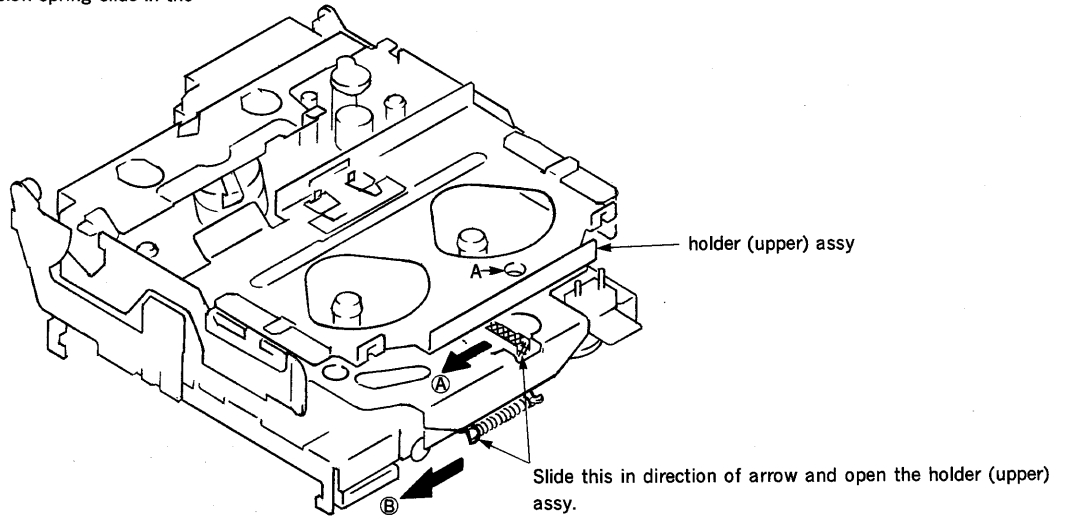

1-2. HOW TO CONNECTION OF TRANSLATION FLEXIBLE BOARDS

Note: On adjustment, connect the translation flexible board as shown below.

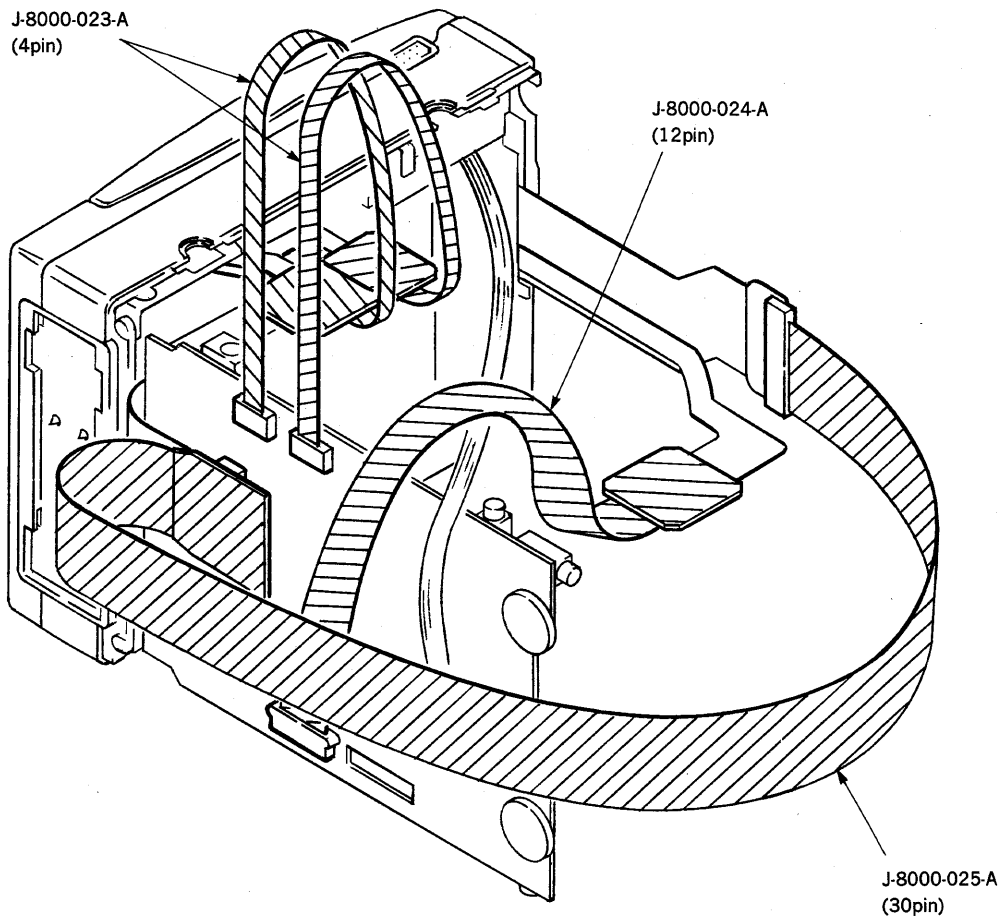

SECTION 2
GENERAL

This section is extracted from instruction manual.

Note
The Serial Copy Management System may not apply to some digital audio tape decks.

Guide to the Serial Copy Management System

What is the Serial Copy Management System
This system permits one generation of digital recording of prerecorded software via the digital input/output. A summary of the rules which this system encompasses is as follows:

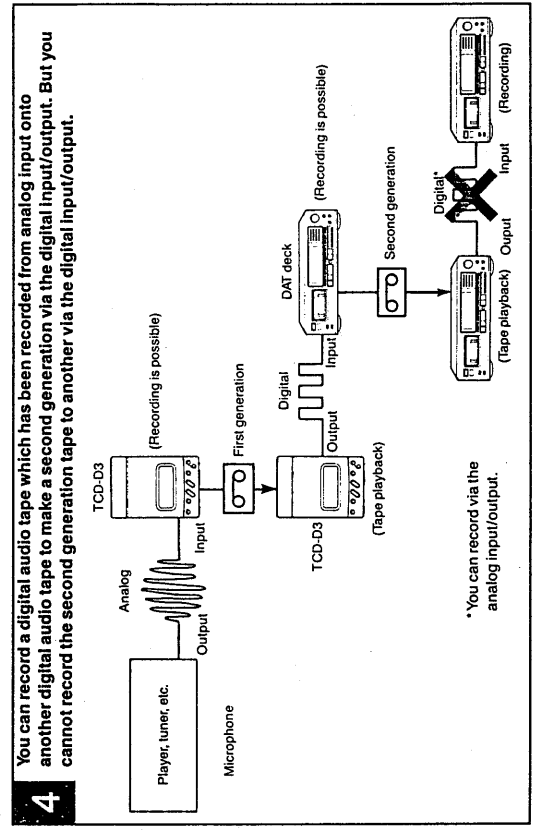
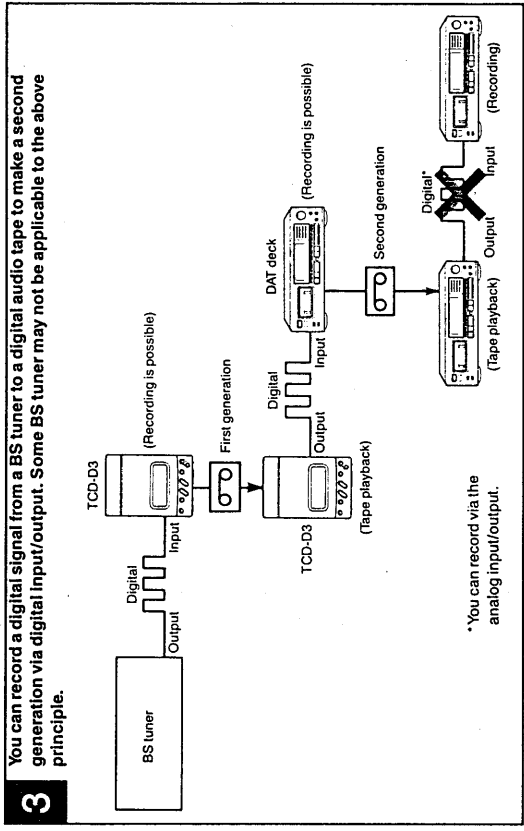
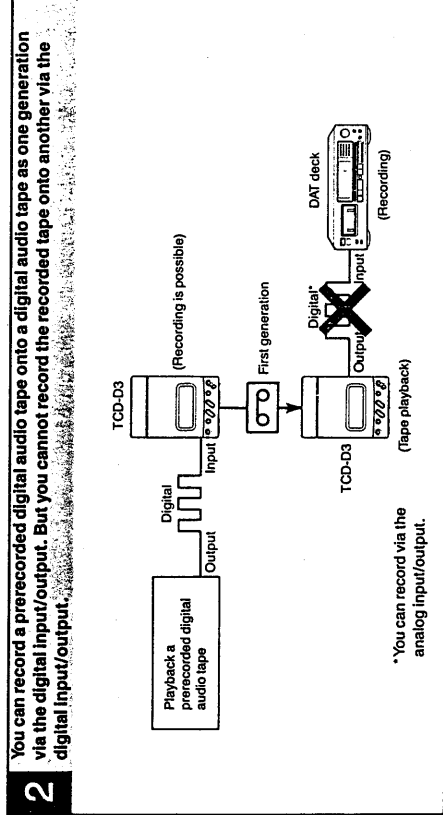
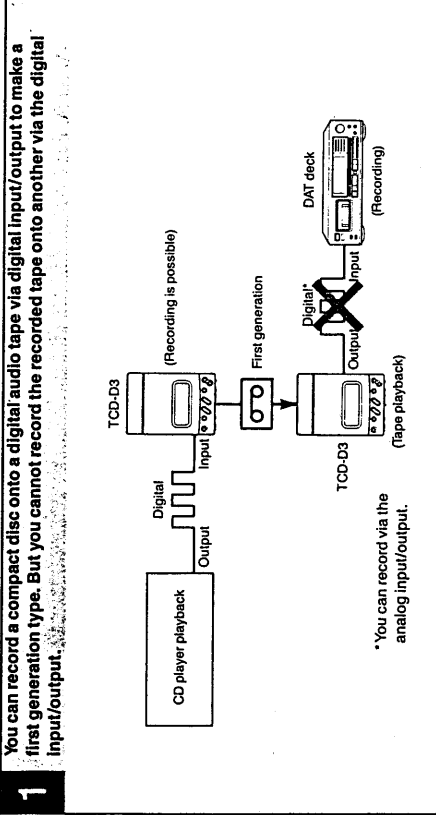

Notes
There are no restrictions for generation when DAT decks are connected via the analog input/output. Therefore, you can record any audio source onto a digital audio tape via the analog input/output even when you cannot record them via digital input/output.

Location and Function of Controls

▶ **PLAY button**—
Press to play back the tape or to check the sampling frequency in the display window during playback or recording.

■ **STOP button**—
Press to stop recording or playback.

◀◀ **REW/REVIEW button**—
In the stop mode, press to rewind the tape. During playback, press to rewind the tape while listening to the sound.

▲ **EJECT button**—
Press when inserting or removing the cassette. This functions as long as when a power source—AC power adaptor, battery pack—is connected even if the power switch is set to off.

▶▶ **FF/CUE button**—
In the stop mode, press to fast-forward the tape. During playback or recording, press to fast-forward the tape while listening to the sound.

|| **PAUSE button**—
Press to stop for a moment during recording or playback. To restart recording or playback, press this button again or press ▶.
If the unit is left in the pause mode for about 5 minutes, it will be automatically released and the deck will enter the stop mode. To restart recording or playback from the stop mode, press REC and ▶ PLAY at the same time when recording or press ▶ PLAY when playing back.

● **REC (recording) button**—
Press to start recording or to monitor the input signal.

PHONES (headphones) jack
Connect headphones to this jack.

POWER switch
Press in the direction of ▶ to turn on the power. Press again to turn off the power. The power will turn off automatically if the stop mode continues for ten minutes when using a battery pack. This helps save the battery power. This function does not work when the power is supplied from the AC power adaptor or car battery cord.

LIGHT (illumination for display window) button
Press this button to illuminate the display window when using the unit in a dark place. Press again to turn off.

VOLUME control
Adjust the volume level of the connected headphones with this control.

BATT RELEASE (battery release) knob
Press this knob in the direction when you remove the battery pack.

MIC ATT (attenuator for microphone) selector
Select to change the sensitivity of an input level from a microphone. Normally, set it to the 0 dB position. If you set it to 20 dB, the sensitivity will be attenuated by 20 dB and the setting can prevent sound distortion caused by high input signals. The selector is effective when recording with microphones.

MIC DC OUT (DC output for microphone) jack
Supplies the power to the ECM-S220 microphone with an auto-power supply system.

LINE IN/MIC (line input/microphone) selector
Select the appropriate position, line input or microphone, according to the connected analog source.

SP/LP (standard play mode/long play mode) selector
Select the mode, standard play or long play, before recording. The unit selects the appropriate mode automatically during playback.

MIC/LINE IN (microphone/line input) jack
You can record an analog signal source if you connect a microphone or line output signal from a stereo system or radio cassette recorder.

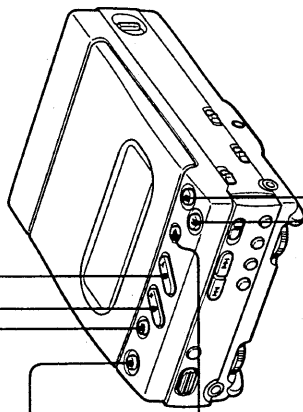

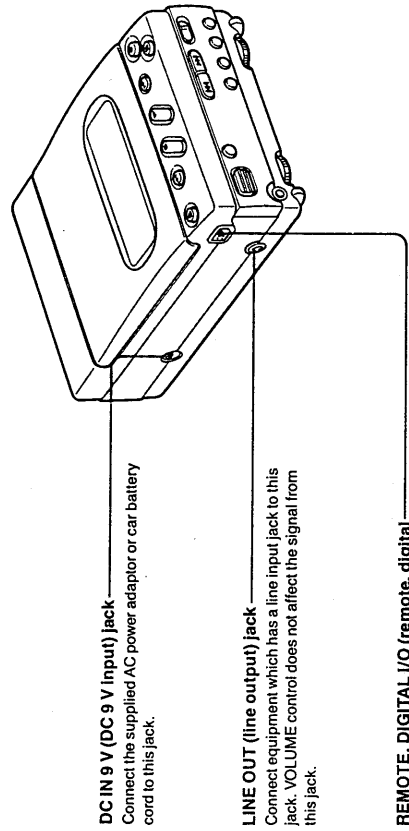
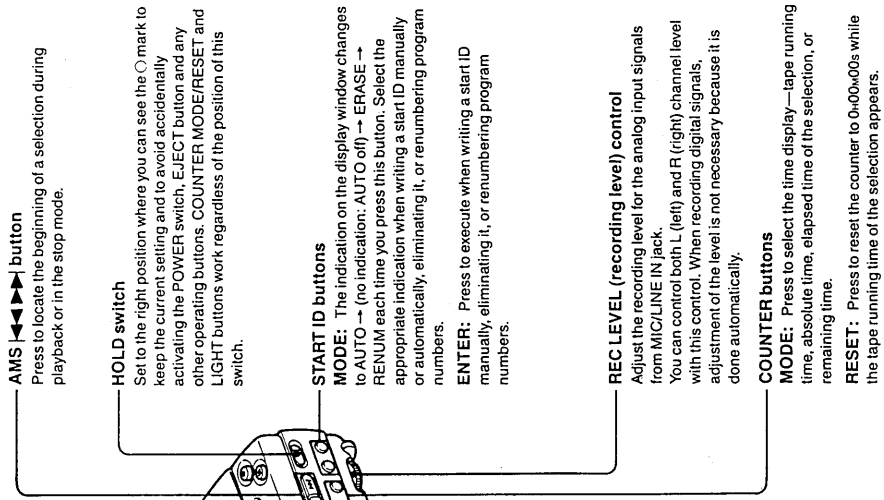

Display window

PGM No. indicator
Shows the number of the selection being played.

- REMAIN (remaining time) indicator**
Lights when the counter shows the remaining time of the tape.
- ABS TIME (absolute time) indicator**
Lights when the counter shows the tape running time from the beginning.
- PGM TIME (program time) indicator**
Lights when the counter shows the elapsed time of the current selection.
During the normal tape counter mode, the above three indicators all go off.

Counter/Indicator for sampling frequency
Displays the linear counter, absolute time, elapsed time of the selection being played, and the total remaining time of the tape. Each time COUNTER MODE is pressed, the display mode changes in turn.
Displays sampling frequency when the **PLAY** button is pressed during playback and recording.

Peak level meters
Indicate peak level of recording or playback signals. In a fast-forward or rewind, **■** mark on the left side meter indicates the direction of the tape running. **■** mark on the right side meter indicates how much tape remains.

- AUTO indicator**
Lights when you set to the AUTO mode to write the start ID automatically.
- WRITE indicator**
Lights when writing the start ID automatically or manually.
- ERASE indicator**
Lights when erasing the start ID is possible.
- RENUM indicator**
Lights when renumbering the program numbers is possible.
AUTO, ERASE and RENUM appear in order each time you press START ID MODE. Set the indicator to off to write the start ID manually.

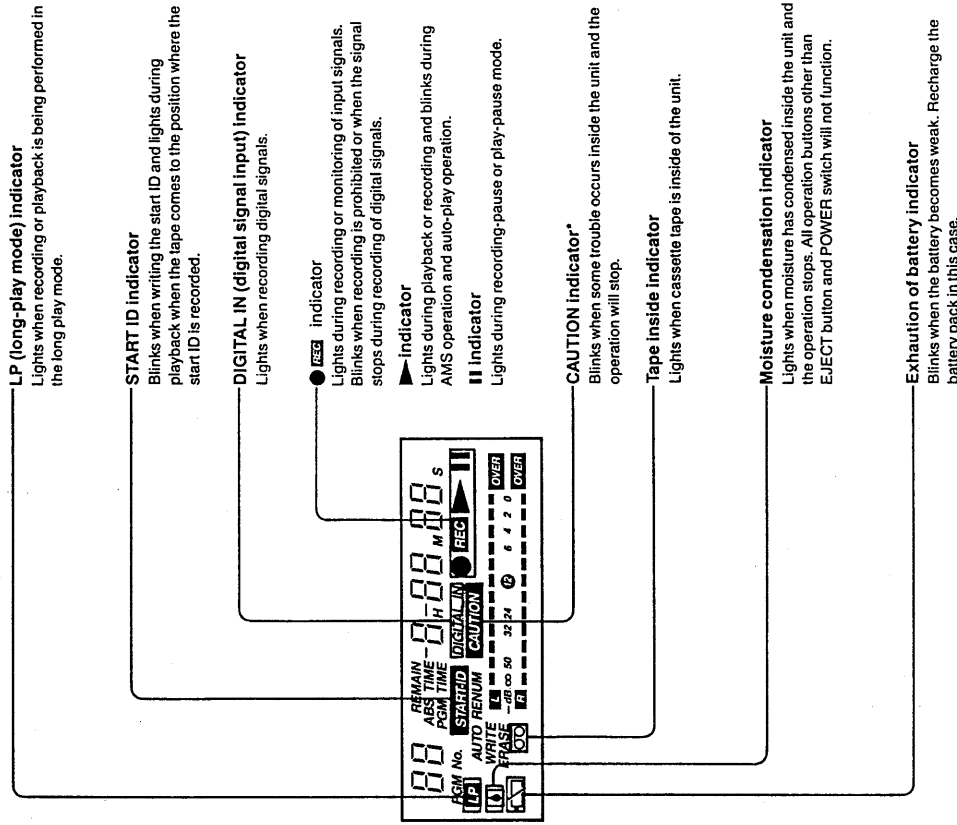
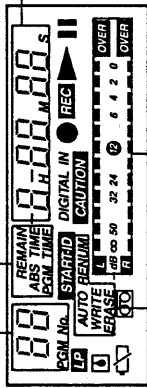

*** On the CAUTION indicator**
Press the POWER switch again when the CAUTION flickers. If the indicator flickers again or flickers frequently during you use the unit, consult your local Sony's dealer or service station after turning off the power.

Power Sources

Using with a rechargeable battery pack

Be sure to charge the supplied rechargeable battery pack.

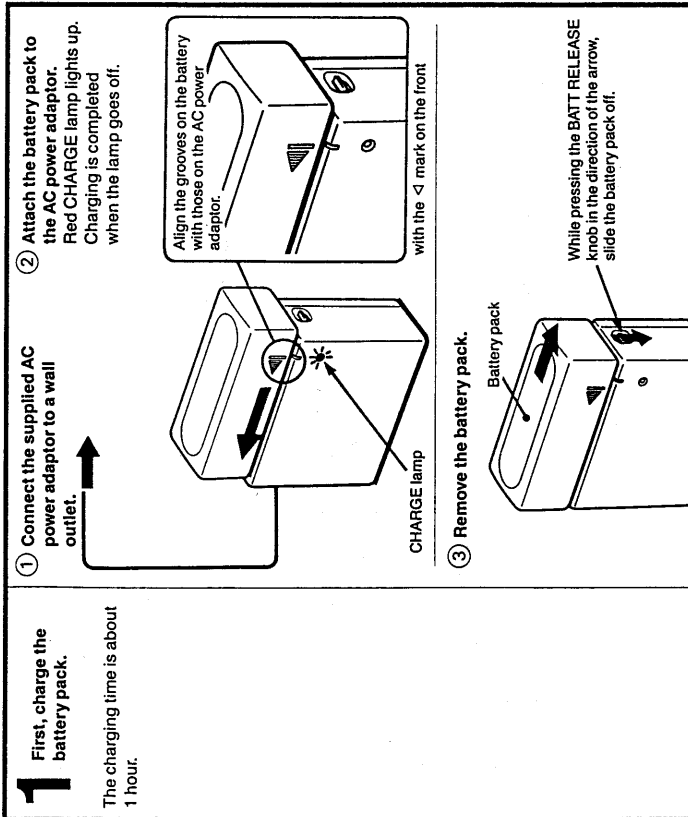

Operating time of the battery pack

A fully-charged battery pack provides approximately 2 hours of continuous use. We recommend that you should prepare more than two battery packs when using DAT-120 or recording in the long-recording mode. If you use the battery pack in a cold place, its operating time is shortened.

When the battery becomes weak The ◀ indication blinks in the display window. Replace the battery pack with a fully charged one after turning off the power. If you leave the unit with the ◀ indication blinking, the unit will be turned off automatically in 5 minutes.

The battery pack heats up
During charging or recording, the battery pack on the AC power adaptor heats up. This is not dangerous.

Life of the battery pack
When the operating time of the fully-charged battery pack becomes short, purchase a new one and use it. Repeated charging while some capacity remains causes a lowering of battery capacity. Recharge the battery only when it is exhausted. (When the ◀ indication begins to blink in the display window, it indicates that the battery pack is exhausted.)

If you plug in the AC power adaptor to the unit while operating the unit with the battery pack The unit stops operating automatically.

Note

On treatment
• Keep the metal terminals on the battery pack away from metal objects, otherwise it may short circuit.

On charging
• Recharge the battery pack only when it is exhausted.
Do not repeat charging, as it will cause the battery capacity to become smaller.
• The battery pack cannot be charged easily in a cold place.
• The original battery capacity can be recovered if you fully discharge and charge the battery several times.

How to care for the battery pack

• Remove the battery pack after it is exhausted and charge it before using it again.
• Remove the battery pack from the unit after using it, and keep it in a cool and dry place. When the battery pack is attached to the unit, a small amount of current flows to the unit even if the power is turned off. This may overdischarge and shorten battery life.

Note on the AC power adaptor

Use only the supplied AC power adaptor. Never use any other adaptors manufactured by Sony because the polarity of the supplied adaptor is opposite of conventional adaptors.



Polarity of the plug

To Record

Connection with other equipment

Recording via digital output
Adjustment of the recording level is unnecessary because it is done automatically.

When you connect TCD-D3 with other equipment directly

There are 2 ways as follow.

- ① If your equipment has an optical digital output
- ② If your equipment has a coaxial digital output

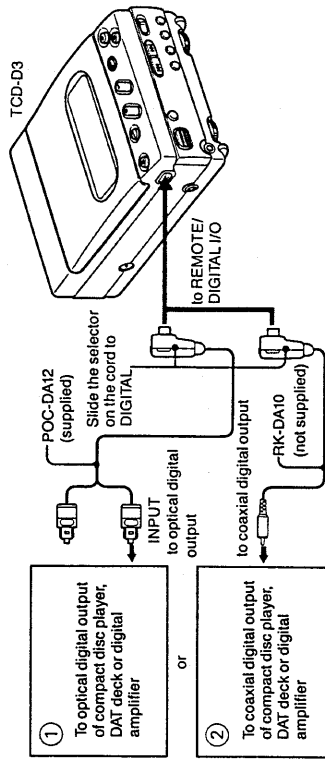

When you connect TCD-D3 with an adaptor kit RM-D3K (not supplied)

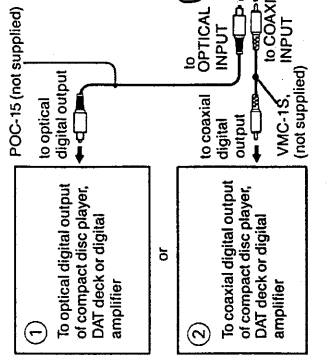

If you connect an RM-D3K (not supplied)
The unit enables recording and playback via digital input/output (optical, coaxial), operation with a wireless remote commander and timer-activated recording or playback with your audio-timer.

If you cannot record via the digital input/output
● **REC** blinks in the window display if a digital signal which cannot be recorded is input to the unit or if the digital signal cannot be input to the unit. Record via the analog input/output in this case.

Recording via analog output
• Slide the selector on the cable or adaptor kit to ANALOG if the connection on page 18 has been done.
• Adjustment of recording level is necessary (See page 28).

When you connect to a stereo system or radio cassette coder through a line output

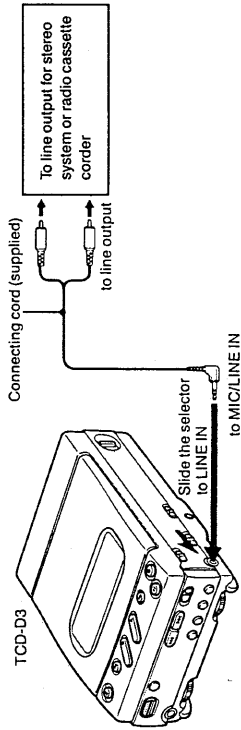

When you connect a microphone

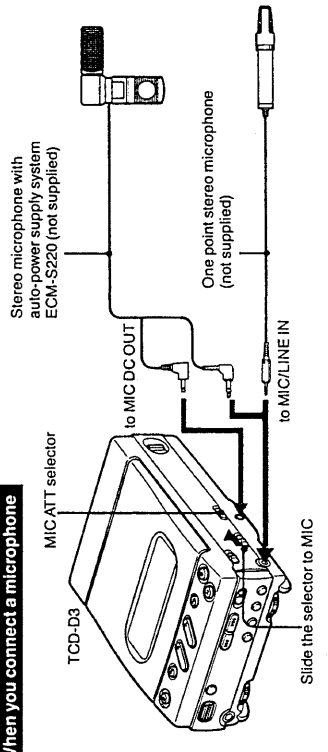

Note

How to use the MIC ATT switch
Set to 0 dB normally. Slide to 20 dB if the level of the input signal is too high causing distortion of the sound.

You cannot use a plug-in power microphone with this unit.

Monitoring the recorded sound
Connection for playback (See page 28 of "To Play Back") is also necessary.

To locate the section to be recorded

Desired location to be recorded	Condition of your tape	Operation
From the beginning	New tape	You can begin to record just after setting the tape. You cannot operate any buttons for several seconds while <i>bb</i> and <i>oP</i> blinks in the display window.
From part way through the tape (from the end of the section you had recorded before).	Wound part way because you had recorded before. New tape, but it has been recorded part way and wound completely.	Begin to record after rewinding the tape to the beginning with the REW button. Forward the tape to the end of the section you have recorded before by pressing the FF button. The tape will stop automatically.
	Recorded tape but it has been rerecorded part way.	Locate the boundary between the first section and the second by listening to the sound. Determine the exact boundary by watching the linear counter in the display window.
	If you have no idea where you had recorded before.	1 Rewind the tape completely. 2 Press the FF button. The point where the tape stops automatically is the end of the section which you have recorded before. If the tape goes forward to the end of the tape, it indicates that the tape has been fully recorded.

The above is necessary to avoid making a blank section on your tapes. See "Note on recording" (page 20) for details.

When you use a new tape for the first time *bb* and *oP* appears in the display window. This shows that BB letters are being recorded on the program number in the read-in section. The read-in section enables you to start recording from the beginning of the tape exactly as well as to write and erase the start ID correctly.

Tape Insertion

Note
Check if the tape can be recorded with the hole covered before inserting the tape (See page 20).

- Window side up
- Tab facing towards you
- Insert the tape correctly

Insert the tape firmly until it clicks.

If you close the holder with the tape inserted incorrectly, it may cause the malfunction.

Press the holder closed. Inside the unit, the tape will be loaded around the head automatically. At this time, you can see *LO RD* blinking in the display window.

When detaching the battery pack or the AC power adaptor from the unit, be sure to do it after closing the holder. You may not be able to close the holder if you detach the above power sources just after opening it. In this case, press the POWER switch after attaching the power sources and close the holder.

To remove the tape

② EJECT

① POWER

Display window

Tape ID
bb

Recording

1 Set the unit before recording.

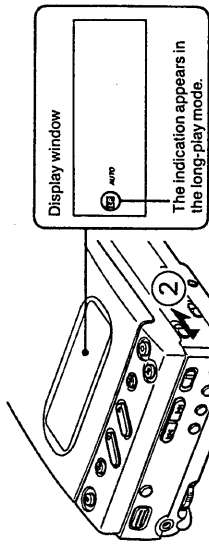

Display AUTO in the window by pressing the START ID MODE button.

Select the recording mode: There are some cases that the long-play mode cannot be used. See page 2 for details.
 SP for standard-play mode
 LP for long-play mode

3 If you record via the digital input by connecting the recommended cord or an adaptor kit FM-D3K, slide the switch on the cord or the adaptor kit to DIGITAL. (See page 2 when you record via the analog input.)

2 Set to the record-pause mode.

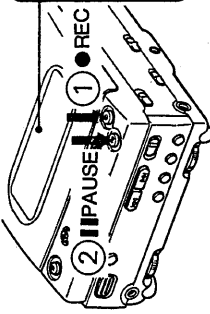

You can do 2 first and then 1.

3 Play your recording source.

4 Release the record-pause mode to start recording.

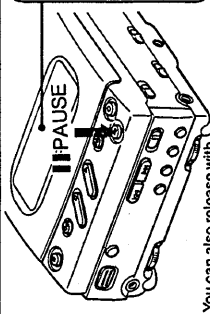

You can also release with the PLAY button.

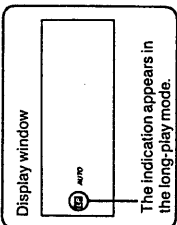

The indication appears in the long-play mode.

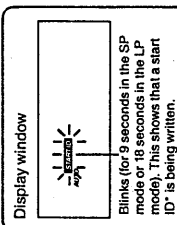
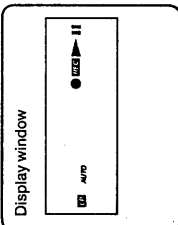

Blinks (for 9 seconds in the SP mode or 18 seconds in the LP mode). This shows that a start ID* is being written.
 *See page 2 about the start ID.

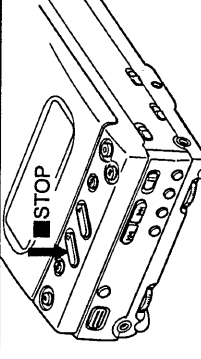
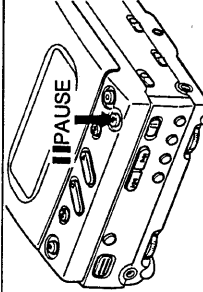
<p>To stop recording</p> 	
	<p>Press the PAUSE or PLAY button to release pause and restart recording.</p> 

If you leave the unit in the record-pause mode for more than 5 minutes

The record-pause mode will be released automatically and the unit will enter the stop mode. This is because of the protection system for the tape and head. Set to the record-pause mode again if desired.

On operation for recording
 You can record by pressing the PLAY button while you press the REC button.

When the tape is recorded to the end (Auto rewind function)
 The tape is rewound to the beginning and stops automatically.

To remove the tape
 Stopping the tape with the STOP button first.

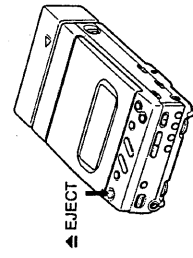

When the input signal is analog
 The following operations are necessary when you record with a microphone or connect a stereo system which does not have digital outputs.

- 1 Select the appropriate position with the LINE IN/MIC selector.**
 MIC When you connect a microphone
 LINE When you connect to the LINE OUT jacks of the stereo system
- 2 Adjust the recording level.**
 How do you adjust to the appropriate level?
 Adjust the peak level meter to light the indication of the segment around 0 (-12 dB) with the REC LEVEL control. The indication does not have to go over 0 dB at the highest level.
 If the indication lights continuously this shows that the level is too high and will cause sound distortion. Re-adjust to the appropriate level.
- 3 Start recording.**

Recording level when the input signal is digital
 It is unnecessary to adjust the recording level. The digital signal is recorded at the same level as the recording source.

Note on recording

Be sure that no blank section is left on the tape when recording.
Blank section: a portion on which a recording has not been made.
Sound-muted section: a portion on which a recording has been made but with the sound muted.

The following is necessary to avoid leaving a blank section on your tape
 Do not advance the tape with the PLAY or FF button. Sound-muted recording can be done to insert silence between selections. Sound-muted recording is done, for example, by recording with the REC LEVEL control at 0 when you record via the analog input or with the REC MUTE button pressed on the adaptor kit RM-D3K (not supplied).
 To start recording from the part way through the tape, locate the beginning of the blank section and start recording. This will avoid leaving a blank section.

The reason why you must not leave any blank sections
 An absolute time code must be written on the tape correctly. If blank sections are left on the tape, the absolute time code is not recorded there and the tape will stop automatically at each blank section needlessly when you forward the tape or try to locate the beginning of the selection.

What is the absolute time code?
 The absolute time indicates the position of the tape, giving the time elapsed from the beginning. The absolute time is recorded automatically at the same time the audio signal is recorded. It cannot be re-recorded. The absolute time allows you to confirm the elapsed time from the start of the tape.

Note

In some cases, the absolute time may not be recorded if you re-record on the tape which the absolute time has not been written.

What is a start ID?

- This signal indicates the start of a music selection. This signal should be written at the beginning of the selection, so that you can locate the position of the start ID precisely.
- If you record with the indication of AUTO in the window, the start ID will be recorded automatically on a tape together with the program number*. We recommend that you record with AUTO in the window.
- * A program number will not be recorded in some cases. See page 3 for details.

Note

- If you record without the indication of AUTO in the window when recording via analog input, the start ID will not be recorded. But you can record it during playback after recording. (See page 9).
- If you record the sound from an other DAT deck via the digital input without AUTO indicated in the window, the start IDs on the master tape can be recorded. However, when recording the sound from other sources via the digital input, they cannot be recorded.

What is a program number

This signal gives a number to a selection. You can record it where the start ID is written.

On the start ID in the AUTO mode

If there is a no sound section or the signal level stays very low for more than about 3 seconds
 A start ID may be written as it is regarded as an interval between two sections.
 An unwanted start ID can be erased later. (See page 3)
 If the auto space function is available with your CD player, activate this function to ensure that the start IDs are written correctly.

The longest recording period in each time

Cassette	The longest recording period		
	standard	long	long
DT-120	2h	4h	4h
DT-90	1h50m	3h	3h
DT-60	1h	2h	2h
DT-46	46m	1h32m	1h32m

(h: hour, m: minute)

You can select the appropriate mode—Standard mode (SP) or Long-play mode (LP)—with the mode selector on the unit.

When is the long-recording/playback unavailable?

The digital input signal on 44.1 kHz or 48 kHz cannot be recorded/played back in the long play mode, even if the mode selector is set to LP. Press the ► PLAY button longer than usual during recording to display and check the sampling frequency of the source program in the display window.

The time counter in the long-play mode
 Absolute time and total remaining tape appears, based on those in the standard mode. To obtain the actual long play time, double each value.

For the customers who have other DAT decks which do not have the long-play mode
 If you playback the tape—which you changed the mode from the standard to the long-play during recording—on other DAT decks which do not have the long-play mode, loud noise may occur at the boundary between the standard mode recorded section and the long-play mode one. Turn down the volume in this case. Same thing occurs when you playback the tape which you made the standard mode recording on which the long-play mode one had been made.

To prevent accidental erasure

When a recording is made, any previously recorded signal will be erased automatically. To prevent accidental erasure, set the safety tab to the position shown in the illustration.

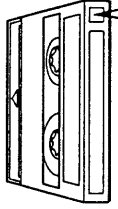

Recording is impossible (with the hole open).

Recording is possible (with the hole covered)

If recording cannot be made

- Check the following:
- The safety tab of the cassette is set to the record-inhibit position.
 - No tape is loaded.
 - The input selector on the unit or the recommended connecting cord, etc., is set to the incorrect position.
 - Tape is fully rewound to the end.
 - The output level of the playback equipment is too low.
 - You are trying to record a signal which cannot be recorded via the digital input. (The ● **REC** indication blinks in the display window.)

If you repeat recording from the beginning of the tape

The sound which was recorded previously may be heard. This is not a trouble.

To Playback

Connection with other equipment

Connection with other equipment which has a digital input

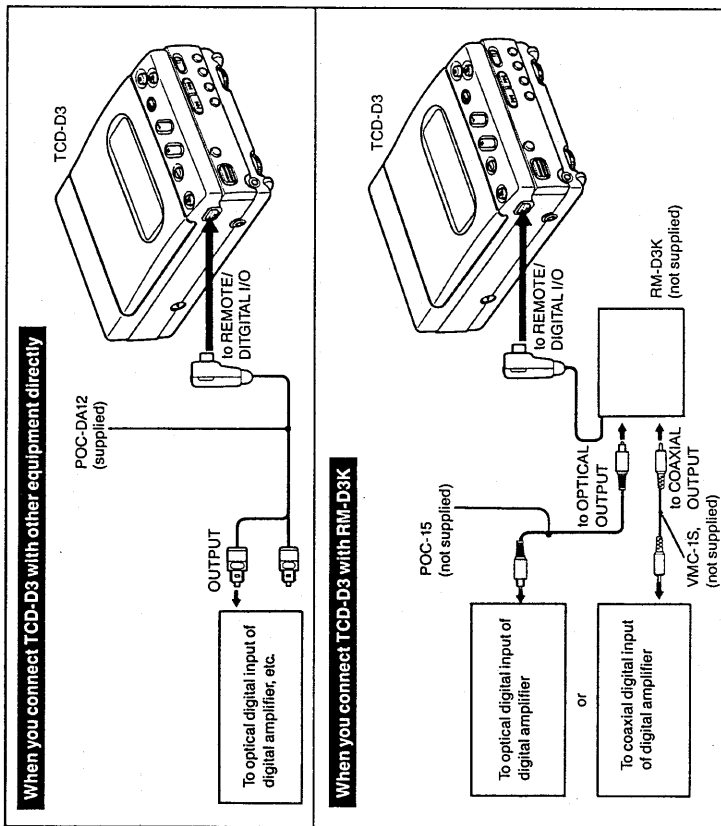

Connection to a stereo system or radio cassette corder through a line input

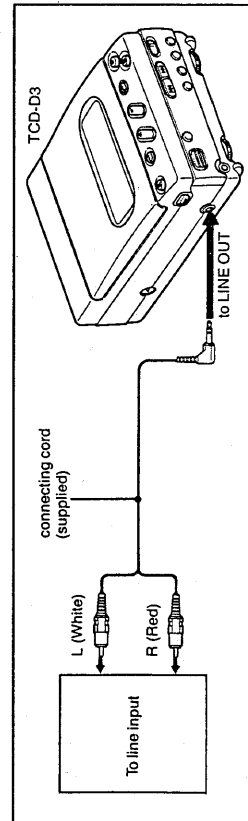

Playback

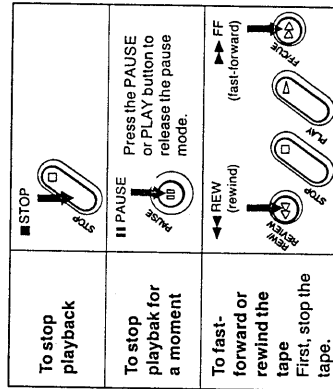
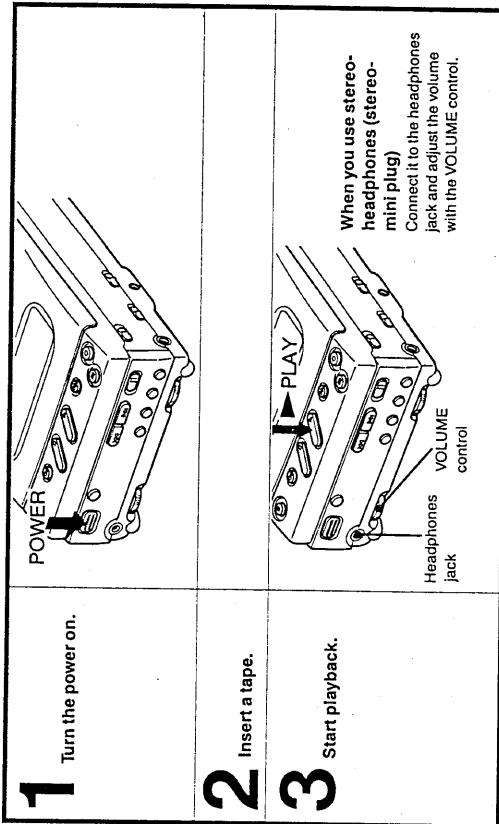

When the tape is played back to its end
The tape will be rewound to the beginning and stop automatically (Auto rewind function)

When you want to rewind the tape and listen to the tape from the beginning
Press the ► PLAY button while you press the REW button. ► indication in the display window blinks while the tape is rewound. The tape will stop at the beginning of the tape and start playback automatically. (Auto play function)

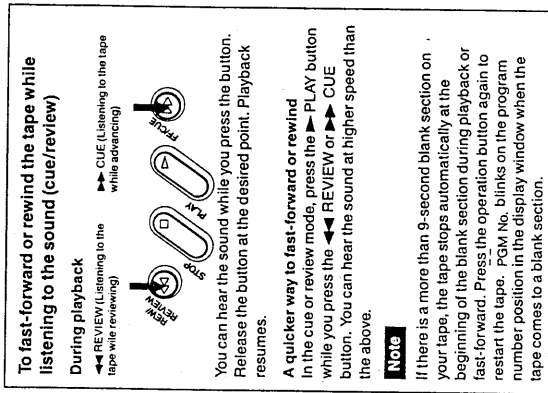

Nice to Know

Locating the beginning of the selection—AMS system

For the following operation, start ID codes must be written on the tape. (For how to write the start ID, see page 29.)

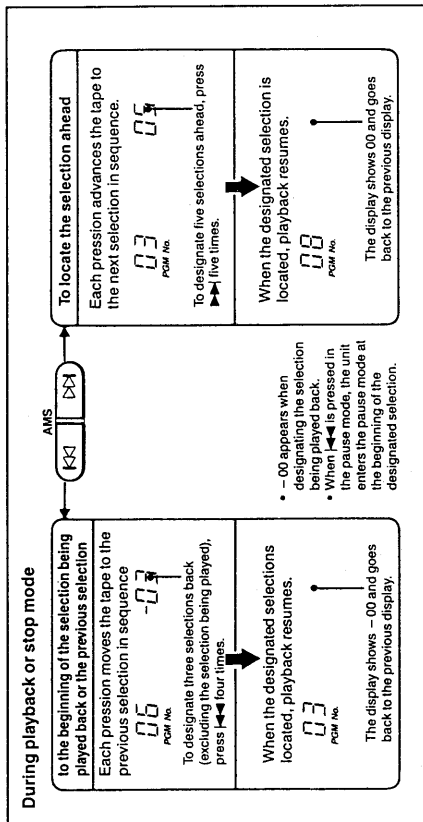

Note

This may not function when you play back the tape which was recorded with other DAT decks.

Using the display window

Each time you press the COUNTER MODE button, the counter changes as follows:

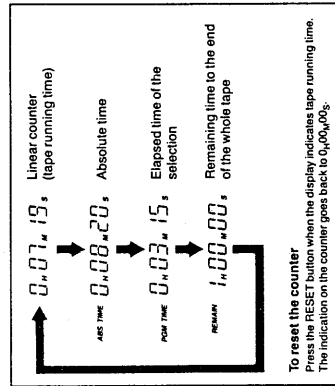

Accuracy of the indicator for the remaining time

Depending on the kind of tape, the indicated time may differ slightly from the actual remaining time.

On start ID

You can write the start ID manually. Usually, the start ID is automatically recorded in the AUTO mode. You can also write it manually by yourself.

- For example, write it manually in the following cases:
 - If you forgot to set the AUTO mode when recording so you get a tape on which the start ID is not recorded.
 - If you want to record the start ID in middle of a selection to locate a particular portion.

Start ID is a convenience for you to locate the beginning of the selection and to edit the tape.

Note

Be sure to check that the safety tab on the tape covers the hole before operating.

Writing start ID manually during recording

Operation	Result
1 Press START ID MODE for a few times.	AUTO or no indication appears in the window.
2 Press START ID ENTER at the desired position during recording.	WRITE lights and START ID blinks in the display window. (9 seconds for standard mode, 18 seconds for long play mode.) Writing is completed.

Writing start ID manually during playback

Operation	Result
1 Press START ID MODE for a few times.	AUTO or no indication appears in the window.
2 Press START ID ENTER at the desired position during playback.	WRITE and START ID blink in the display window, and a 3-second portion from the point where you press START ID ENTER, is played back repeatedly (rehearsal function). The beginning of the repeated portion will be beginning of the start ID.
3 Press START ID ENTER again if the position is the desired one.	WRITE lights and START ID blinks while the start ID is written. You cannot hear the sound at this time.

Adjust the position if there is a gap between the position where the start ID is written and the desired one. (See page 29.)

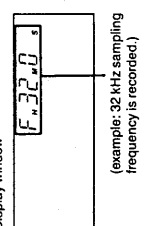

How to adjust the start ID position

You can shift the start ID position about 0.3 seconds backward or forward with **REW/REVIEW** or **FF/CUE** during rehearsal play. Press **ENTER** after shifting it to the desired position. The start ID cannot be shifted except in the rehearsal mode.

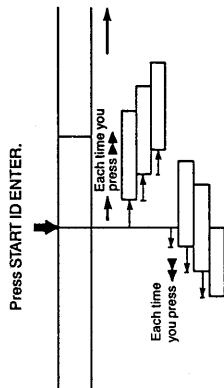

After the repeated portion is played back 16 times, the tape stops.

Note

- You must adjust the position within ten seconds.
- You cannot activate any operation buttons other than **STOP** while the start ID is being written.
- When **WRITE** and **ERASE** blink quickly during rehearsal play, the start ID cannot be written.
- The program number cannot be written when the start ID is written during playback.

On program number

If **AUTO** appears in the display window when recording from the beginning of the tape, the program number is automatically written together with start ID. Renumber it in the following cases because it may not be written or it may overlap.

- The succeeding program numbers are not written because you started recording from the middle of the tape.
- The same program number may be written twice on the tape because you have recorded from the beginning to the middle of a tape on which another recording was made.
- When you write a start ID during playback.
- If you erase the start ID, the program number will be automatically erased. This means that there may be some missing numbers on the tape.

Unless you renumber the program numbers, it may be inconvenient for you because the same program number may appear twice or you cannot select the desired selection with the numeric button on the adaptor Kit RM-D3K (not supplied).

Note

This may not function when you write or renumber the program numbers on the tape which was recorded with other DAT decks.

Erasing start ID

Locate the tape at beginning of the desired start ID to be erased. You can erase it during playback or stop mode.

Operation	Result
1 Locate the tape at the beginning of the desired start ID to be erased.	
2 Press START ID MODE a few times.	ERASE appears in the display window.
3 Press ENTER during playback or stop mode.	The tape is rewound and the start ID is searched for. ERASE blinks during this time. ↓ The start ID is erased after being detected. ERASE lights and ERASE blinks at this time. You cannot hear the sound.

Note

The program number is erased at the same time you erase the start ID.

Renumbering program numbers

Be sure to check that the safety tab on the tape covers the hole before operating.

Operation	Result
1 Press START ID MODE a few times.	RENUM appears in the display window.
2 Press ENTER during playback or stop mode.	<ul style="list-style-type: none"> The tape will automatically be rewound to the beginning, and the program numbers are renumbered from "1" in order at each start ID position. At that time, you can hear the beginning of the section for 3 seconds. The tape will be rewound to the beginning again and the number will be written without sound. The unit will repeat at each section. ERASE blinks while the program numbers are renumbered. RENUM blinks while the tape is fast-forwarded to the next start ID. If the pre-recorded program number is correct, the unit searches for the next start ID.

When renumbering is completed

The tape is automatically rewound to the beginning, and the function of the unit stops.

Erasing program number

Refer to "Erasing start ID". The program number will be erased together with the start ID.

SECTION 3 DISASSEMBLY

Note: Follow the disassembly procedure in the numerical order given.

3-1. LOWER PANEL ASSY

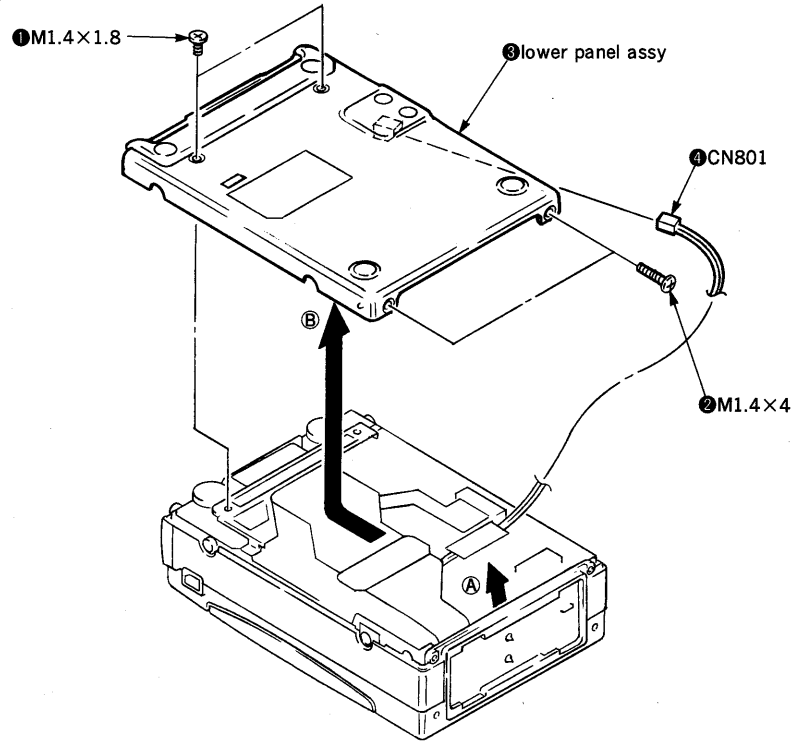

3-2. MAIN BOARD

Note: On assembly board, take notice of put each switches and knobs position.

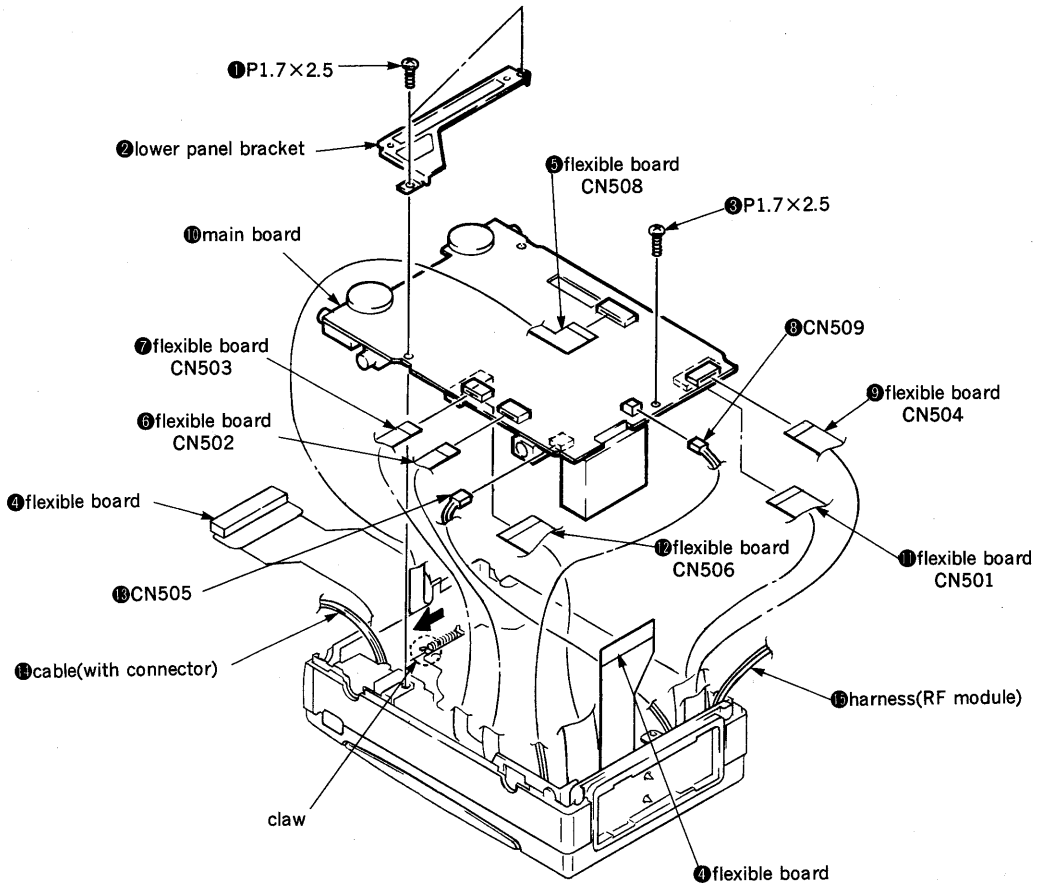

3-3. CASSETTE LID ASSY

① Turn on the POWER switch, open the cassette lid by press the EJECT button.
 Or to do disassembly ① to ⑩ of "3-2. MAIN BOARD", slide the claw of MD block while raise the main board and open the cassette lid.

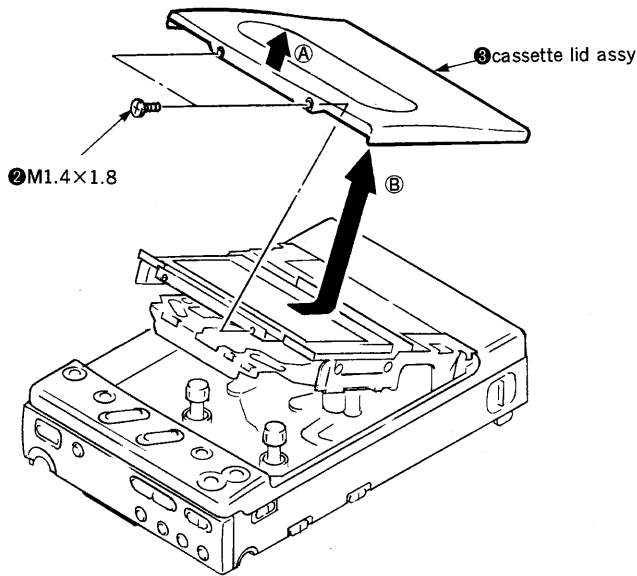

3-4. CABINET(UPPER) ASSY

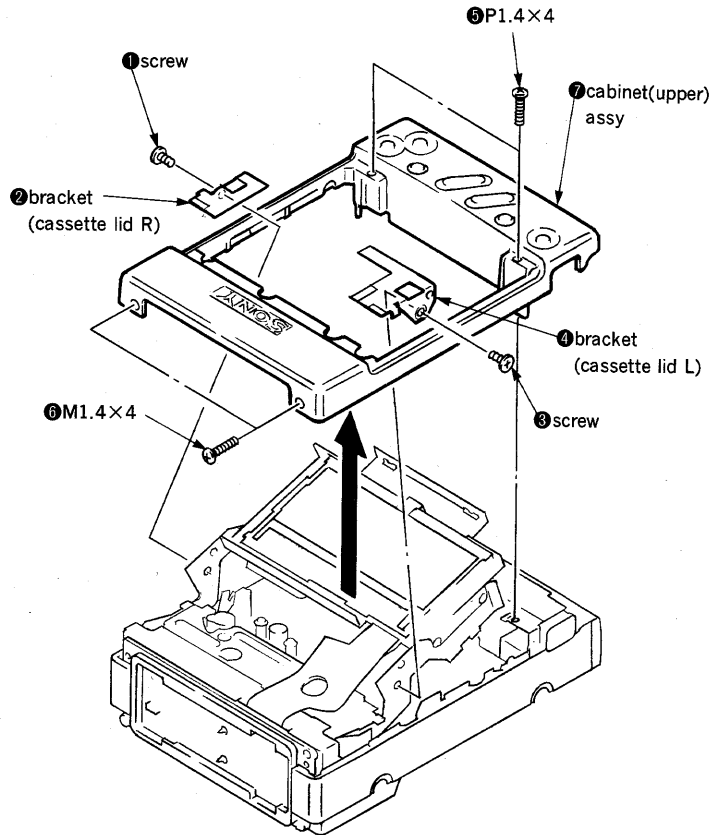

3-5. CONTROL PANEL ASSY

Note: On assembly side ornamental belt (R) assy, take notice of put each switches and knobs position.

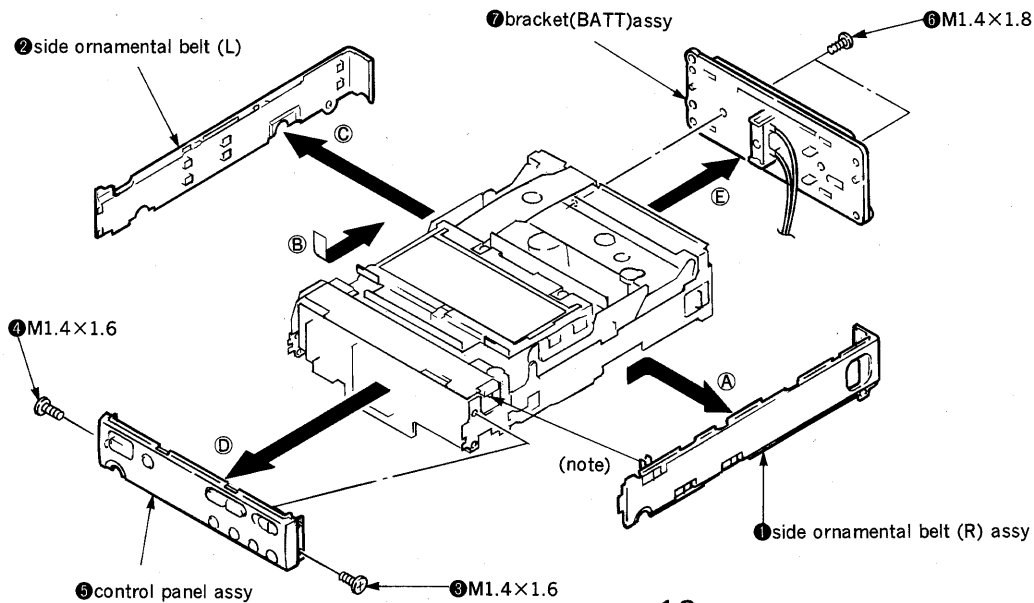

3-6. CHASSIS

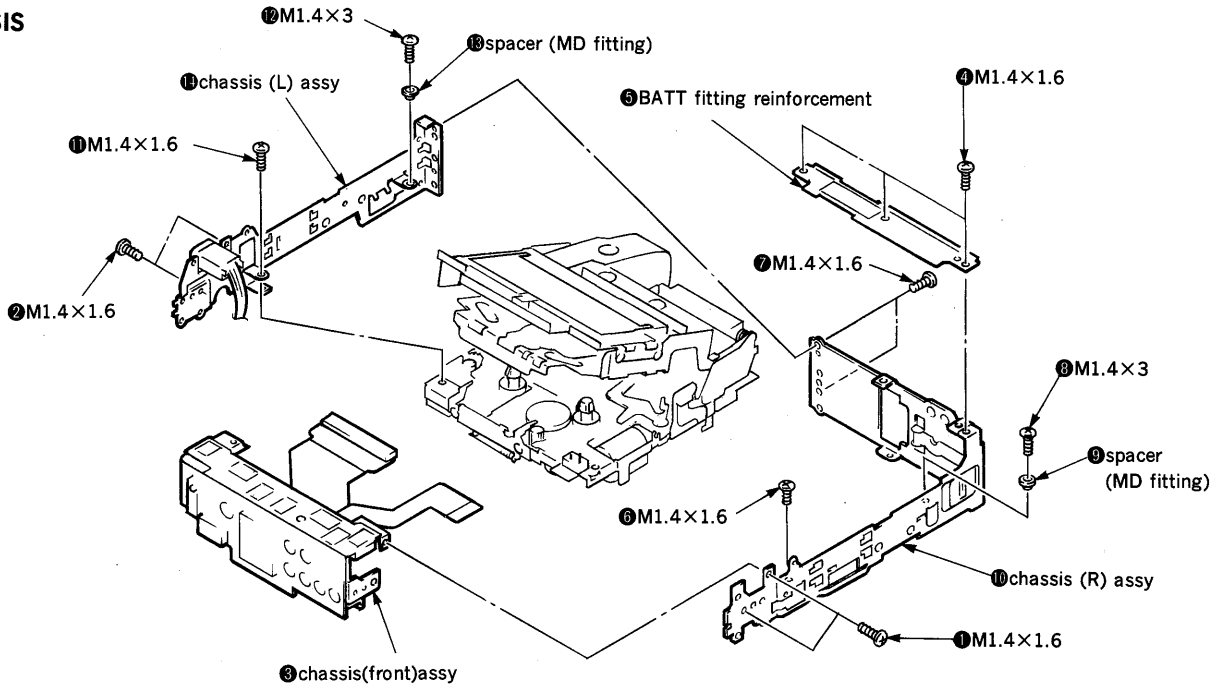

3-7. LCD ASSY

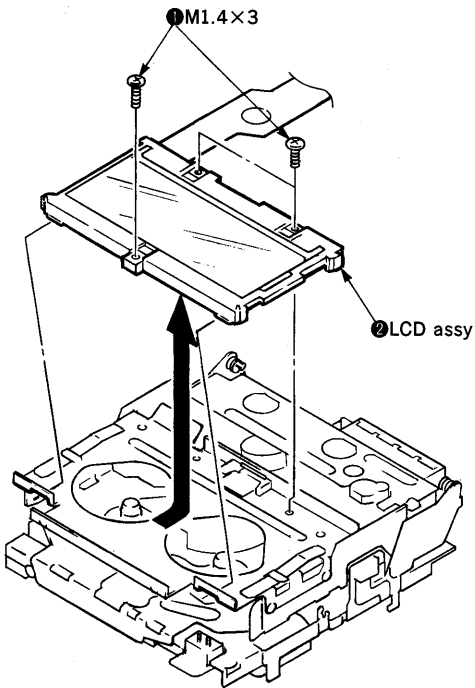

3-8. DRUM ASSY

On load state at MD, turn the capstan motor by finger and unload state.

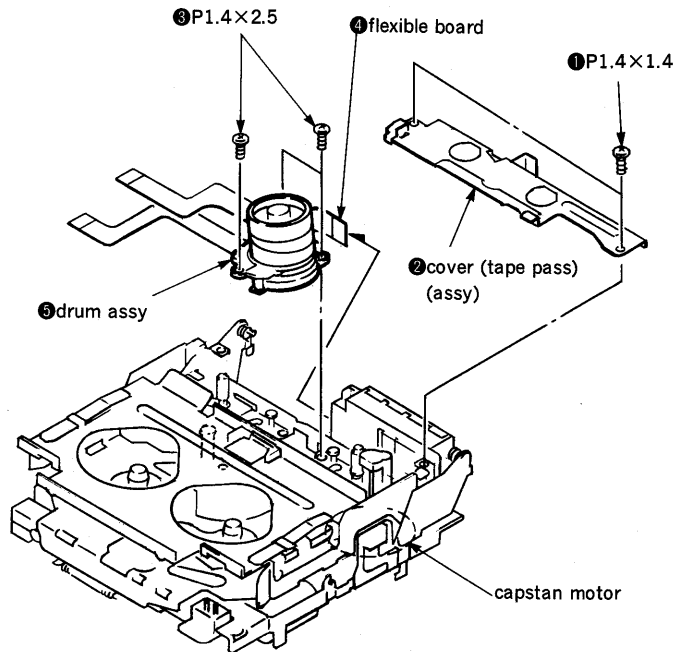

SECTION 4-1 ADJUSTMENTS

4-1-1. NOTE FOR THE ADJUSTMENTS

1. Perform the adjustment following the procedures.
2. Use the following test tapes.
 - TY-7111 (8-909-812-00) : Level
 - TY-7915 (8-913-932-00) : Tape pass, SWP
 - TY-30B (8-892-358-00) : Blank
 - TY-7551 (8-909-814-00) : Music
 Use the following torque meter.
 - TW-7131 (8-909-708-71) : FWD, back tension
3. Position of the switch and the control
 - LP/SP (S601).....SP
 - HOLD (S617).....Release side (the opposite side of →)
4. Supply DC 6.0V from the DC IN jack for the power source.
5. When cleaning the drum, supply a little alcohol to the chamois (2-034-697-00) or the four or more piled knit, put it on the drum, and rotate the drum counterclockwise. (twice or three times)
6. When measuring with the main board stand use the translation flexible boards.
 - 30P translation flexible board (J-8000-025-A)
 - 12P translation flexible board (J-8000-024-A)
 - 4P translation flexible board (J-8000-023-A) 2pcs.
 Refer to the "SECTION1 SERVICE NOTES" for the connecting of the translation flexible boards.

4-1-2. TEST MODE

1. Set the test mode before the adjustments.
Be sure to release the test mode after the adjustments.
2. Solder the TEST MODE tap on the main board.
3. Turn ON the POWER button.
 - The back light of the LCD lights and the initial display appears as follows.
 - The mechanism section is loaded and the segment in the command part of the LCD display flashes. (It keeps on flashing.)

Initial display of the LCD (When the POWER button is turned ON, the following display is always appeared.)

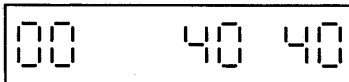

4. LCD display and display selecting

Every time the LIGHT button is pressed, the test mode display and the counter mode display is alternately selected.

• Test mode display

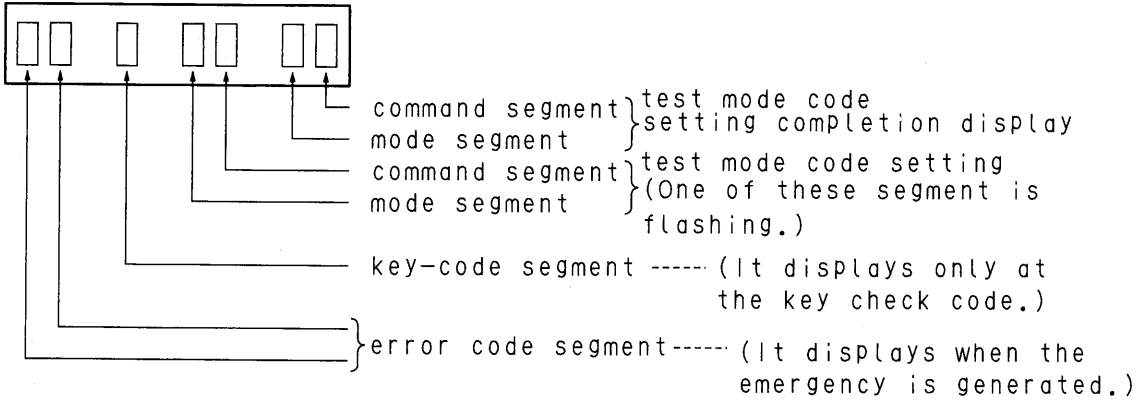

• Counter mode display

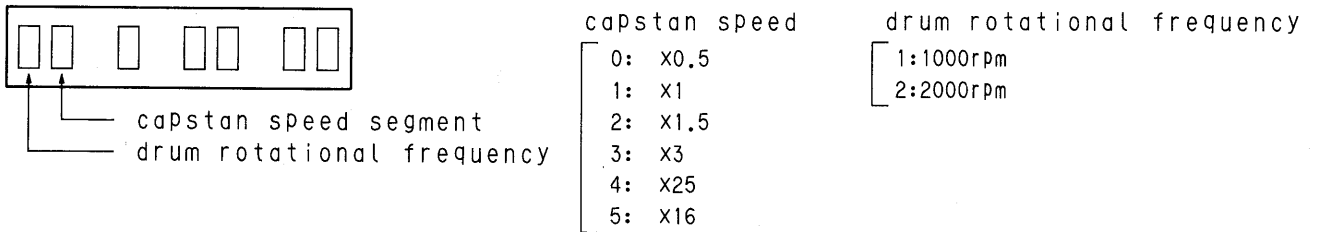

5. Setting of the test mode code

a. Every time the COUNTER MODE button is pressed, the flashing of the segment position of the mode and the command is selected.

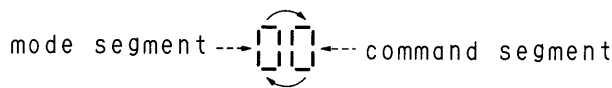

b. Every time the COUNTER RESET button is pressed, the value of the segment is changed.

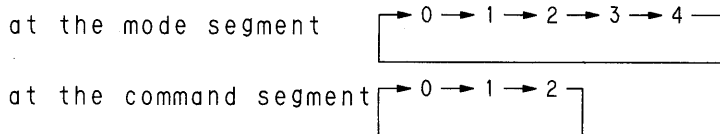

c. The test mode code is set with pressing the ENTER button. (The segment is flashing during the setting even after the setting is completed.)

6. Mechanism section operation method on setting of the test mode code

● 40mode.....Mechanism only check mode (Regardless of the attachment of the tape)

- a. Press the START ID MODE button.....It is unloaded.
- b. Press the COUNTER RESET button.....It is loaded.
- c. Press the AMS ►► button -----
- d. Press the AMS ◄◄ button -----

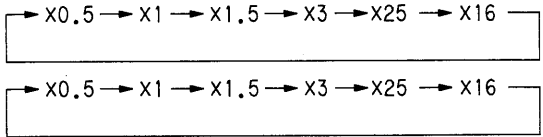

(Note) Perform the procedures of a and b when the counter is displayed.
Perform the procedures of c and d when the test mode or counter mode is displayed.

● 42mode.....Mechanism adjustment mode (When the tape is attached)

- a. Press the AMS ►► button -----
- b. Press the AMS ◄◄ button -----

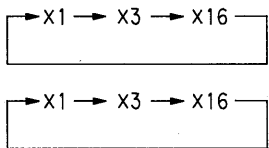

7. Explanation of test mode code

00.....Normal mode

The condition in this mode is the same as the one when the TEST MODE tap is not soldered. When setting the test mode again from this mode, turn OFF the and then turn ON POWER again.

10.....LCD and KEY test mode (automatic)

When the code is input and the ENTER button is pressed, the automatic walking mode is set. When the sequence is completed, the test mode is displayed. Lighting time of each segment is half second.

11.....LCD and KEY test mode (manual)

When the code is input and the ENTER button is pressed, the manual walking mode is set, And every time the COUNTER MODE button is pressed, the display of the segment is changed. When the sequence is completed, the test mode is displayed.

12.....KEY check mode

When the code is input and the ENTER button is pressed, the KEY check mode is set. When each buttons is pressed, the code according to the each buttons is displayed in the key code segment.

Button Name		Code No.
REW/REVIEW	◄◄	1
STOP	■	2
PLAY	►	3
FF/CUE	►►	4
REC	●	5
PAUSE		6
AMS(REW search)	◄◄	7

Button Name		Code No.
AMS(FF search)	►►	8
COUNTER MODE		9
COUNTER RESET		A
START ID MODE		b
ENTER		c
LIGHT		d

When finishing this mode, set the other mode and press the ENTER button.

30.....End sensor check mode (FWD mode)
This mode is not attached the test tape.

31.....End sensor check mode (FF/REW mode)
This mode is not attached the test tape.

When the START ID button is pressed after the code is input and the ENTER button is pressed, the driving of the end sensor LED (D1001) starts.

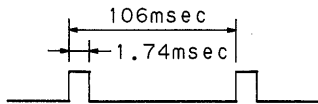

—The LED driving waveform at FWD—

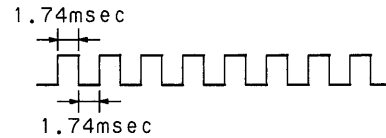

—The LED driving waveform at FF/REW—

40.....Mechanism only check mode

This mode can be regardless of the attachment of the tape.

When the tape is not attached at FF/REW and at $\times 25$ FWD/ $\times 25$ REW, the regulated voltage drive is operated, while the servo is operated when the tape is attached.

41.....Regulated voltage drive mode

In this mode, the drum and the capstan is operated with the regulated voltage with pressing the PLAY button.

42.....Mechanism adjustment mode

This mode is effective only when the tape is attached. The speed of the drum and the capstan is displayed when the counter mode is displayed.

8. Error code list

Code No.	Block	Contents
00		No error (No emergency)
01—09	Control motor (Encoder)	The position can not be detected. *
10	Mechanism deck	The loading is not completed.
11		The unloading is not completed.
12		Not ejected.
13		End sensor is no good. (T reel side)
14		End sensor is no good. (S reel side)
15		DEW detection.
20	Drum	The drum motor is not rotated.
21		The drum servo is not locked.
30	Capstan	The capstan motor is not rotated.
31		The speed is not detected.
40	Reel	T reel FG is not detected.
41		S reel FG is not detected.
42		The measurement is not completed.

* When the position of the rotary encoder is not detected, the number with "0" before the position number corresponded with the position is displayed as the error code. (Refer to appears as follows)

EJECT	:01	Load	:04	FF	:07
Unload	:02	FWD	:05	STOP	:08
CASIN	:03	REV	:06	REW	:09

When the emergency is generated in the each test mode, the error code is displayed.

4-1-3. ADJUSTMENT PARTS POSITION

—mechanism section—

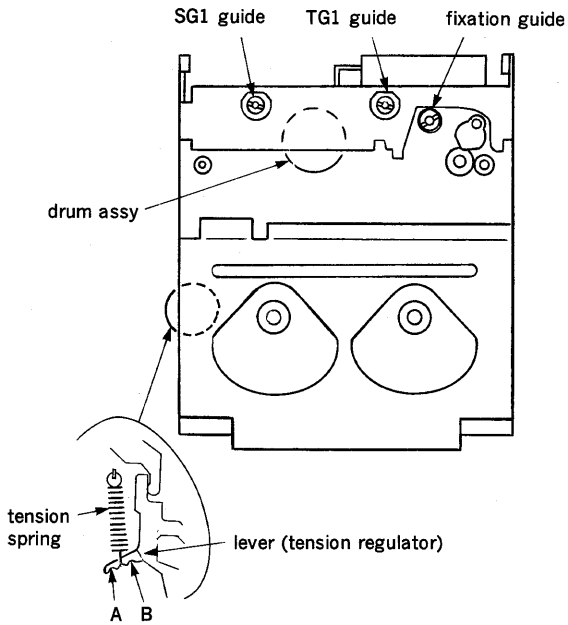

—main board—

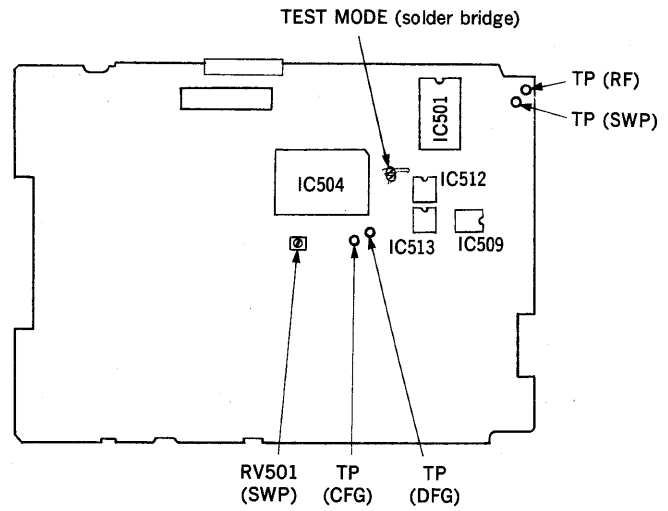

**SECTION 4-2
MECHANICAL ADJUSTMENTS**

Note) Be sure to perform the adjustment when the drum is replaced.
In case of tape pass check only, confirm the 6 to 13 items.

4-2-1. TAPE PASS ADJUSTMENT

1. Set the test mode and attach the test tape TY-7915 and rotate the test tape to center.
2. Set the test mode code 42, and press the AMS ►► button. (×1 FWD)
3. Lower the SG1 guide (clockwise), and drop out the test tape. (Figure-1)
4. Lower the TG1 guide (clockwise) and drop out the test tape (figure-2), and then turn counterclockwise so that the right edge of the RF waveform is a right angle as shown in the figure-3.
5. Turn the SG1 guide counterclockwise so that the left edge of the RF waveform is a right angle as shown in the figure-4.

—RF waveforms—

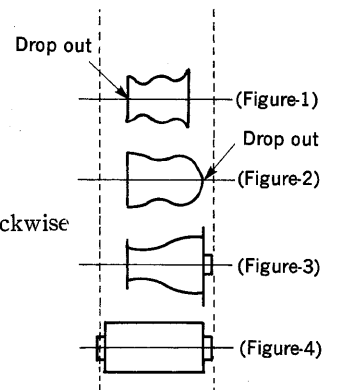

At this time, the lower flange of fixation guide should not contact with the test tape. And the test tape is rotate along the upper flange of SG1 and TG1 guides.

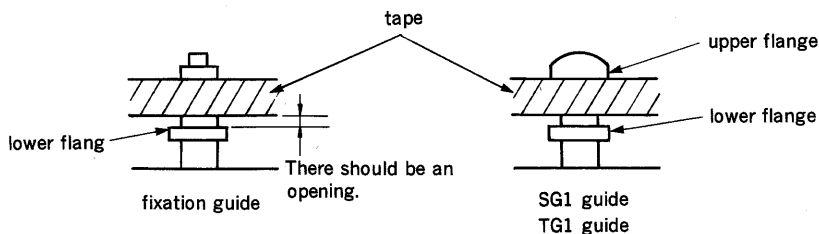

6. Check the RF waveforms.

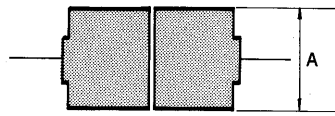

(Figure-5)

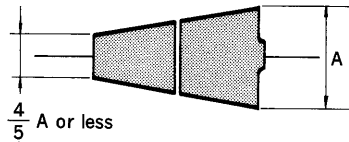

NG

(Figure-6) ⇨ Fine adjust the SG1 guide so that waveform of figure-5.

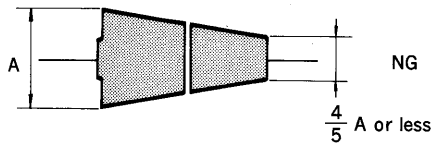

NG

(Figure-7) ⇨ Fine adjust the TG1 guide so that waveform of figure-5.

Note) SG1 and TG1 guides is not adjust mutually. Adjustment of one side is completed and later, adjust another guide of one side.

7. Press the LIGHT button, and set the counter mode display.
 8. Press the COUNTER RESET button or the START ID MODE button, and offset the tracking. (Until the waveform becomes 1/2A)

COUNTER RESET button.....positive direction
 START ID MODE button.....negative direction

9. Check that the waveform when the tracking is offset. (Positive direction and negative direction)

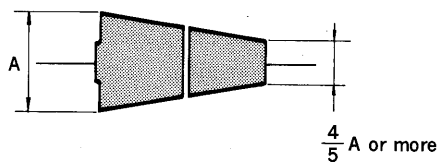
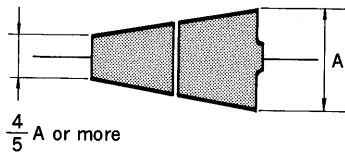

10. Press the COUNTER RESET button or the START ID MODE button, return the tracking offset to 00.
 11. a. Press the STOP button and later, press the EJECT button and remove the test tape.
 b. Set the test tape again, and press the AMS ►► button. (×1 forward)
 c. Check the peak value and the width of the change of the RF waveform.

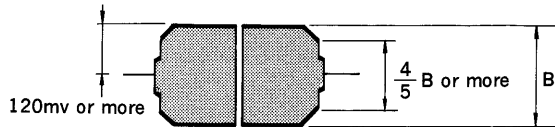

- d. In case of RF waveform is not satisfied to check value, repeat the 6 to 11 iters.

12. Press the AMS ►► button or the ◀◀ button, and set the ×1 forward or the ×1 reverse.
 Adjust the fixation guide so that the lower flange of fixation guide is along the test tape. (No tape curl)

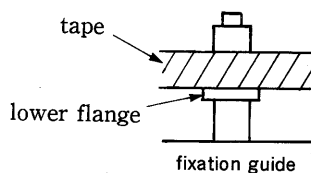

13. Press the FF, REW, CUE and REVIEW each buttons, check the stable the RF waveform.

4-2-2. END SENSOR CHECK

1. Set the test mode.
2. Set the test mode code 31.
3. Check that the display of the error code segment is 00.

4-2-3. TORQUE CHECK

Preparation

Remove the LCD block from the holder (upper).
(×1FWD)

1. Set the test mode.
2. Set the test mode code 40.
3. Attach the torque meter TW-7131.
4. Press the AMS ►►► button and set ×1FWD.
5. Check the torque meter.

Take up torque 4.0—7.5g•cm
(0.056—0.104oz•inch)

Back tension 3.0—5.5g•cm
(0.042—0.076oz•inch)

6. In case of back tension is not satisfied to check value, change the position A or B for tension spring hung on the lever (tension regulator) and check again.

(×3REV)

1. Perform the same procedures as in the above items from 1 to 3.
2. Press the AMS ◄◄◄ button and set ×3REV.
3. Check the torque meter.

Take up torque 6.0—11.0g•cm
(0.083—0.153oz•inch)

Back tension 6.0—12.0g•cm
(0.083—0.167oz•inch)

4-2-4. SPEED CHECK

(Capstan FG)

1. Connect the frequency counter with the TP CFG.
2. Set the test mode.
3. Set the test mode code 40.
4. Attach the test tape TY-30B.
5. Press the AMS ►►► button, and read the frequency at ×0.5 FWD, ×1FWD, ×1.5FWD, ×3FWD, and ×16FWD.

Mode	Frequency
×0.5FWD	296Hz±5Hz
×1FWD	592Hz±5Hz
×1.5FWD	888Hz±3Hz
×3FWD	1776Hz±3Hz
×16FWD	9471Hz±7Hz

(Drum FG)

1. Connect the frequency counter with the TP DFG.
2. Perform the same procedures as in the above items from 2 to 4.
3. Press the AMS ►►► button, and read the frequency at ×0.5FWD and ×1FWD.

Mode	Frequency
×0.5FWD	400Hz±1Hz
×1FWD	800Hz±1Hz

SECTION 4-3 ELECTRICAL ADJUSTMENTS

Note) Be sure to perform the adjustment when the drum is replaced.

4-3-1. SWP (Switching Pulse) ADJUSTMENT

Preparation) Oscilloscope CH-1 : AC 100mV/DIV
 CH-2 : DC 2V/DIV
 TRIG : CH-2

1. Connect the CH-1 of the oscilloscope with the TP RF and connect the CH-2 with the TP SWP.
2. Set the test mode.
3. Set the test mode code 42.
4. Attach the test tape TY-7915.
5. Press the AMS ►► button and set $\times 1$ FWD.
6. Adjust the period (T) between the SWP waveform and the RF waveform with the RV501.

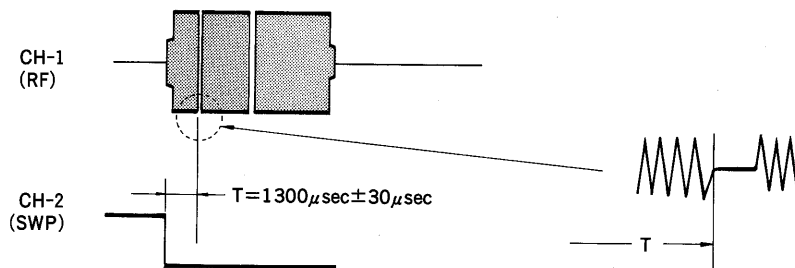

SECTION 5 DIAGRAMS

5-1. CIRCUIT BOARDS LOCATION

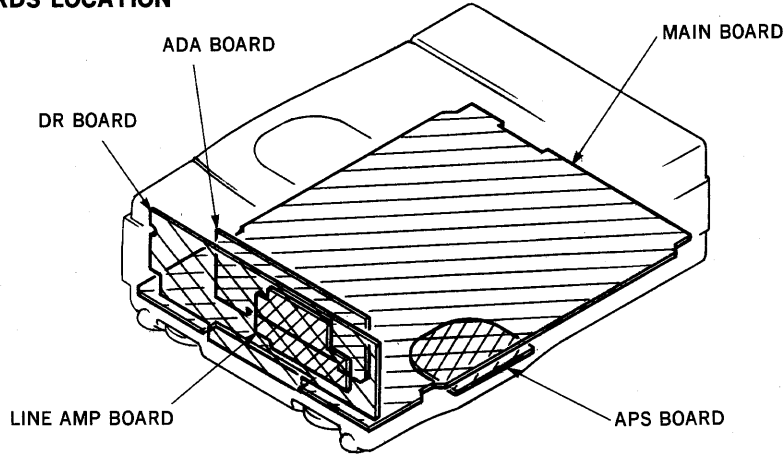

5-2. SEMICONDUCTOR LEAD LAYOUTS

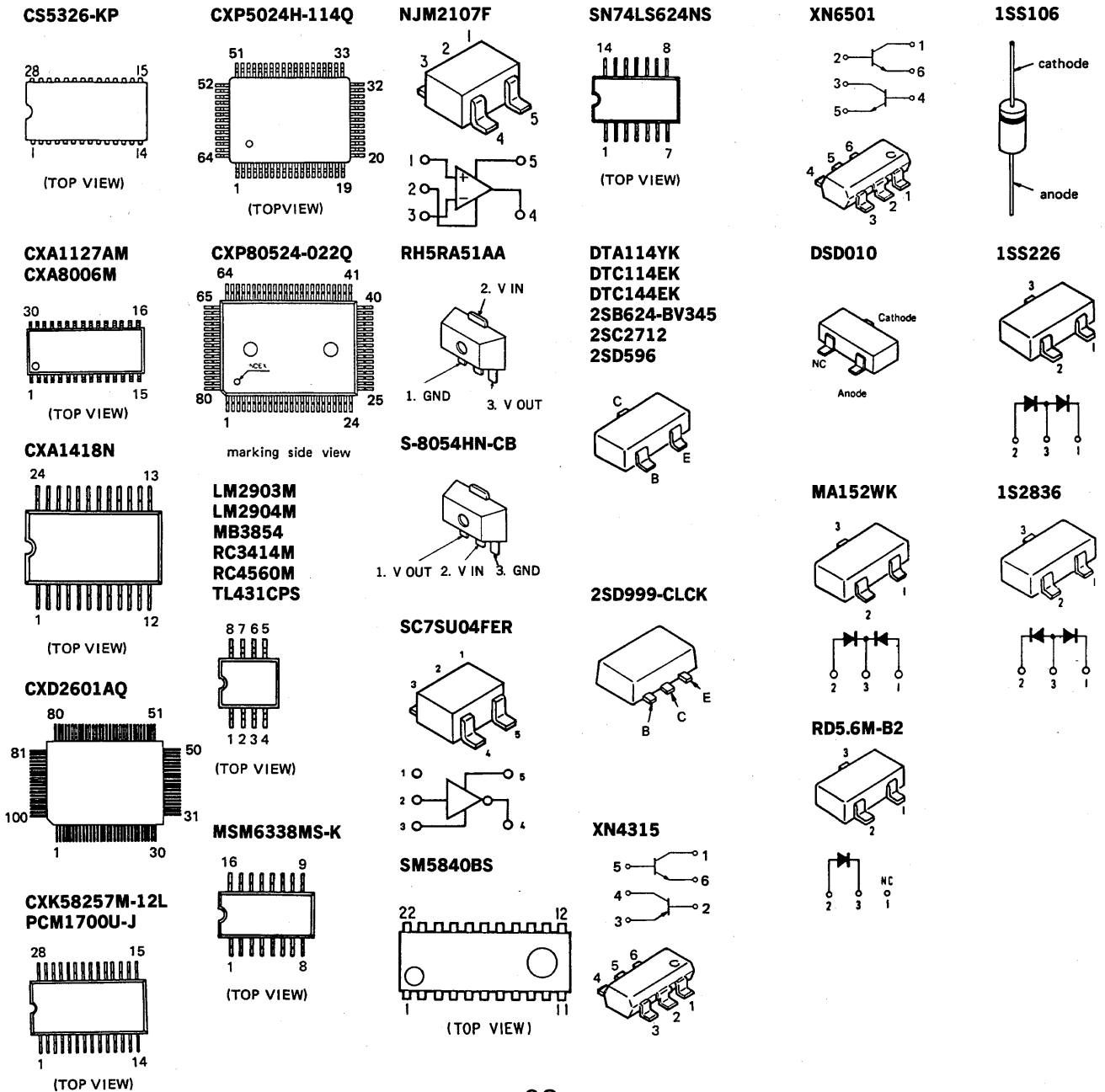

● Semiconductor Location
—System control/ servo section—

Ref. No.	Location
D301	E-3
D304	F-24
D305	I-23
D501	D-21
D502	E-23
D503	B-19
D504	B-19
D505	G-12
IC301	C-23
IC302	E-24
IC303	H-23
IC304	F-3
IC501	B-11
IC502	G-10
IC503	G-8
IC504	D-8
IC505	B-18
IC506	G-11
IC507	G-11
IC509	D-11
IC510	I-21
IC511	I-6
IC512	D-11
IC513	D-11
IC514	C-21
IC515	F-6
IC516	G-22
IC517	D-5
IC518	F-10
IC519	E-22
IC520	D-21
IC521	D-21
IC525	D-22
Q101	I-4
Q102	I-3
Q201	I-3
Q202	I-2
Q301	D-3
Q302	E-4
Q303	G-4
Q501	G-17
Q502	F-10
Q503	D-4
Q505	F-21
Q506	F-21
Q507	E-21
Q1001	E-31
Q1002	F-27

5-4. PRINTED WIRING BOARDS —SYSTEM CONTROL/SERVO SECTION ● Refer to page 28 for Semiconductor Lead Layouts.

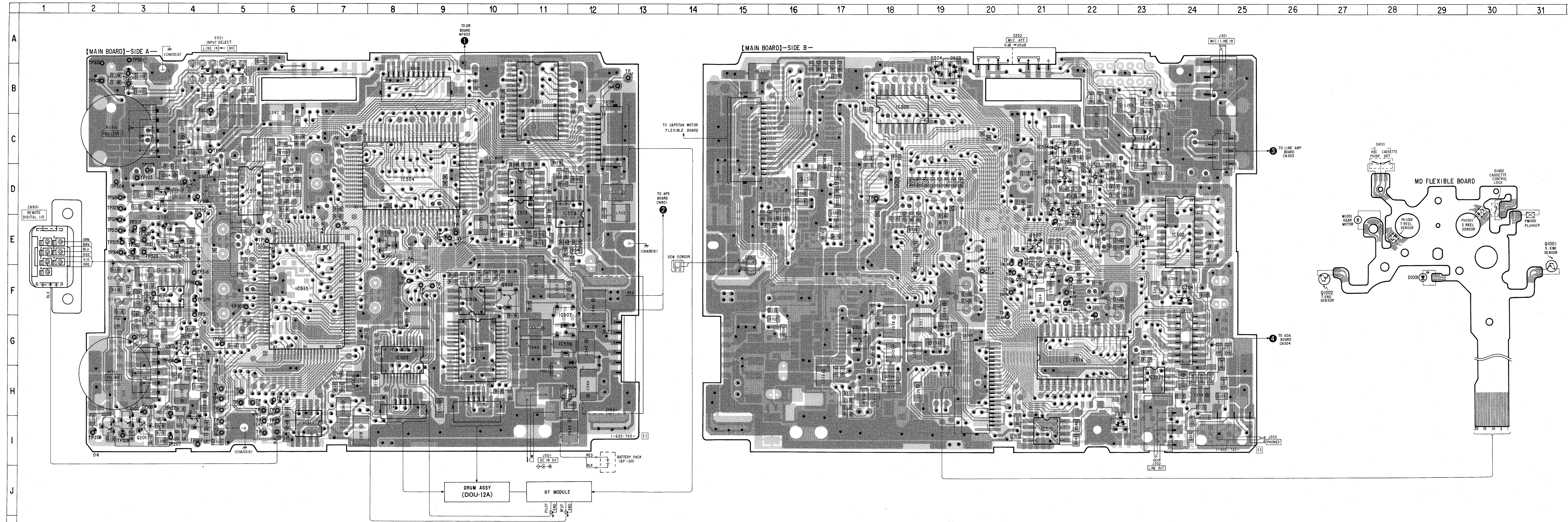

Note:
 ● ○ : parts extracted from the component side.
 ● ○ : parts extracted from the conductor side.
 ● ■ : parts mounted on the conductor side.
 ● : Through hole.
 ● : Pattern on the side which is seen.
 ○ : Pattern of the rear side.
 ● : Through hole with 2layer.
 ● : Through hole with 3layer.

5-7. PRINTED WIRING BOARDS —AUDIO/DISPLAY SECTION • Refer to page 28 for Semiconductor Lead Layouts.

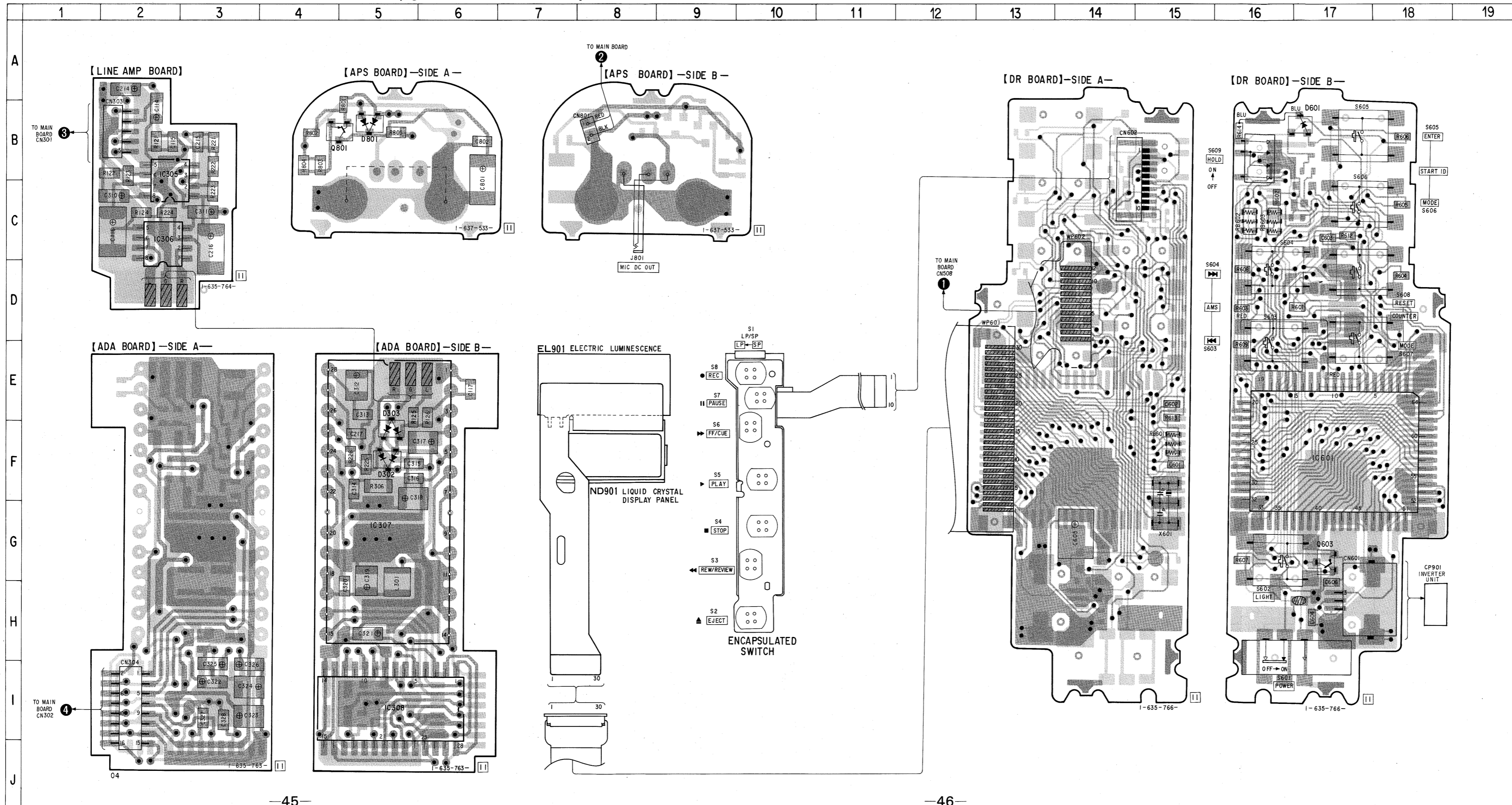

• Semiconductor Location —Audio/display section—

Ref. No.	Location
D302	F-5
D303	F-5
D601	B-17
D801	B-5
IC305	B-2
IC306	C-2
IC307	G-5
IC308	I-5
IC601	F-17
Q603	G-17
Q801	B-5

Note:

- — : parts extracted from the component side.
- — : parts extracted from the conductor side.
- • : Through hole.
- : Pattern on the side which is seen.
- : Pattern of the rear side.

• IC Block Diagrams

IC302 SM5840BS

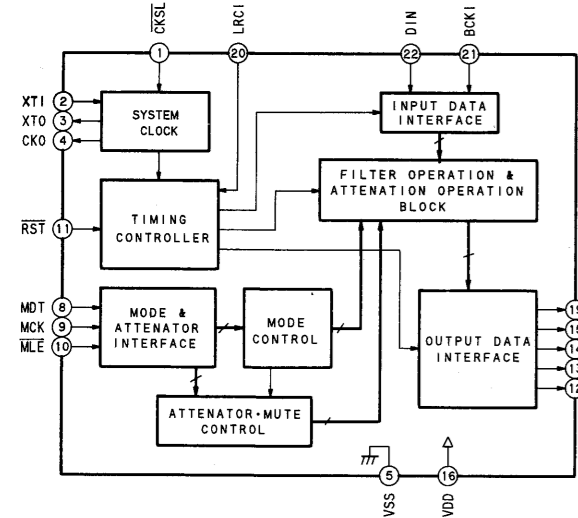

IC307 CS5326-KP

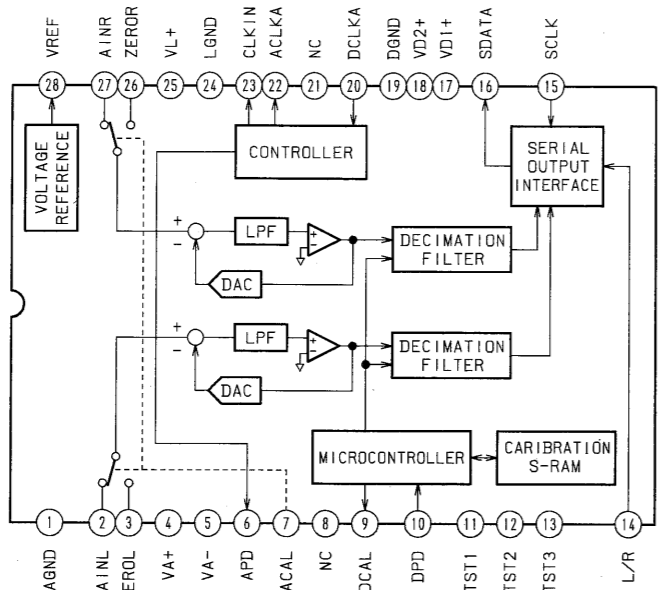

IC308 PCM1700U-J

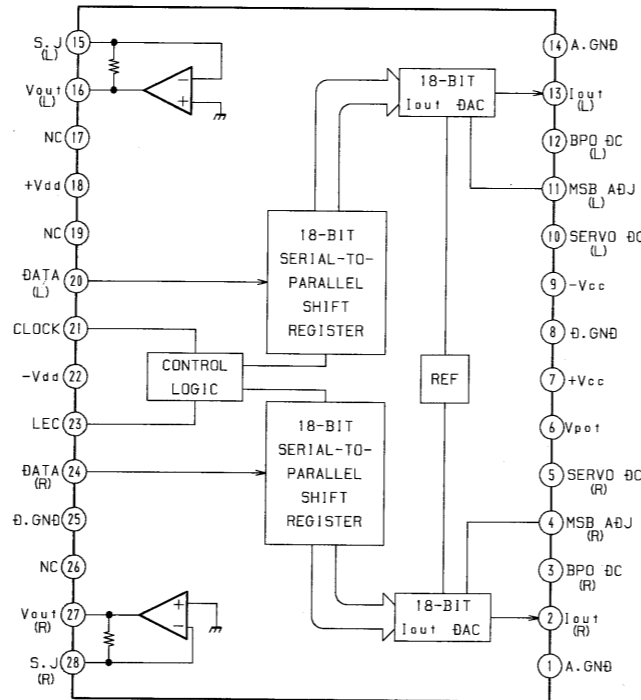

IC517 SN74LS624NS

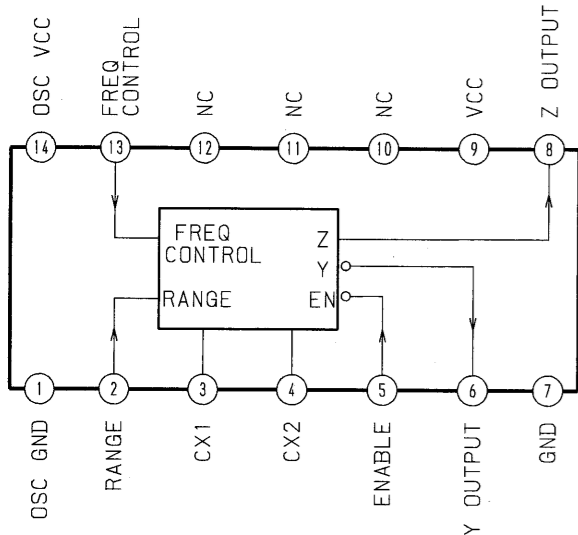

IC503 CXA1418N

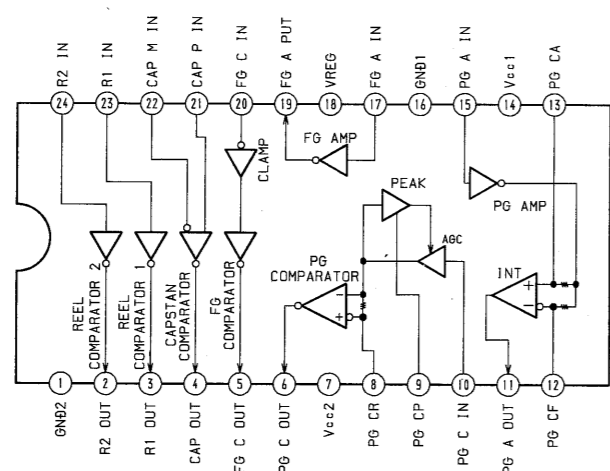

IC511 MB3854

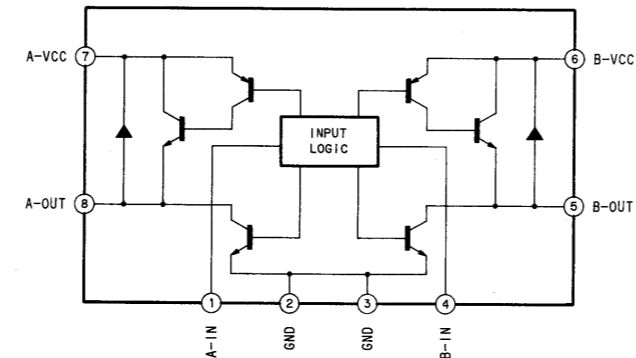

IC501 CXA1127AM

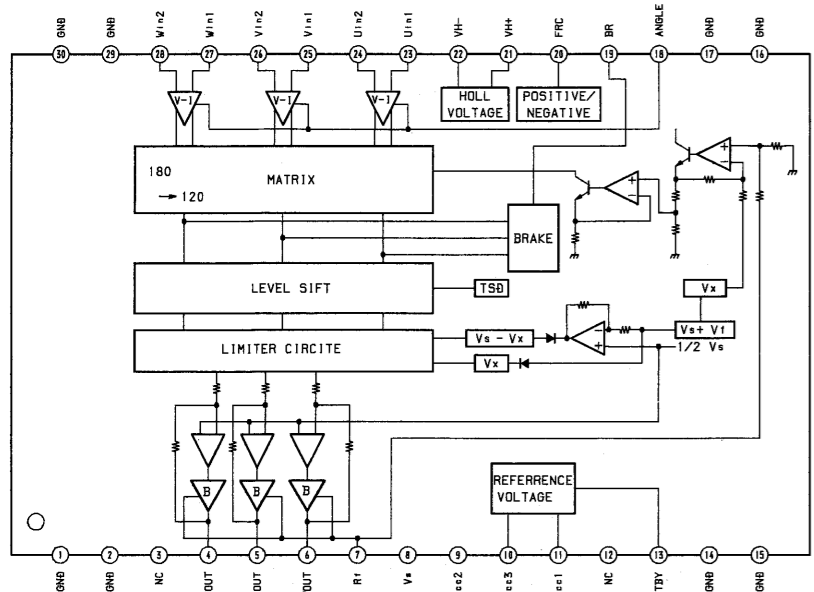

IC502 CXA8006M

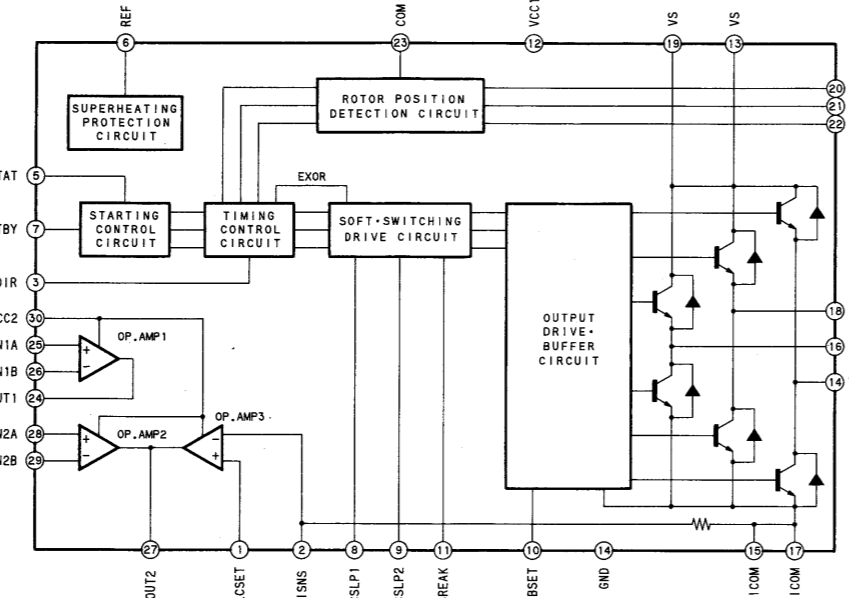

• Waveforms

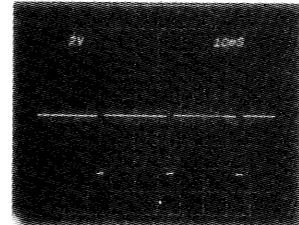

1 IC504 (1)



7 IC503 (5), IC504 (58) (TP DFG) PLAY MODE

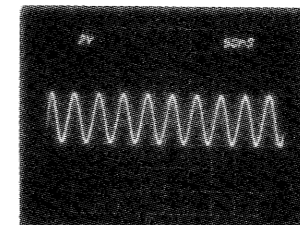

13 IC515 (13) PLAY MODE

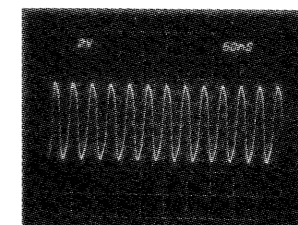

14 IC515 (66)

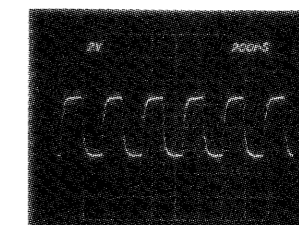

24 IC307 (14) (TP307)

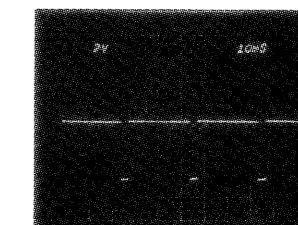

11 IC601 (4)

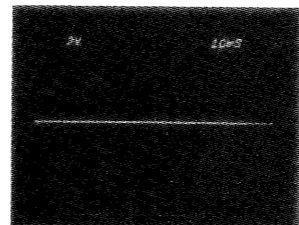

2 IC504 (7-10, 19-22)



4 IC503 (4), IC504 (57) (TP CFG) PLAY MODE

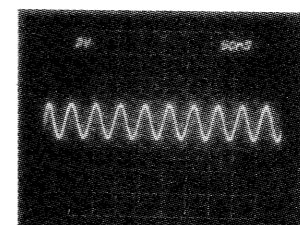

15 IC515 (14)

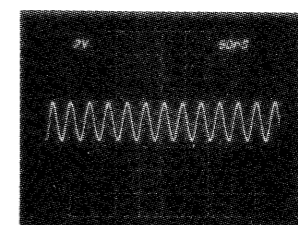

20 IC515 (67)

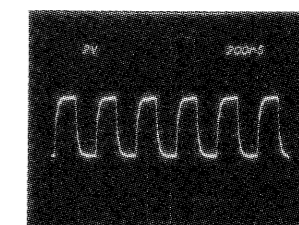

26 IC307 (15) (TP308)

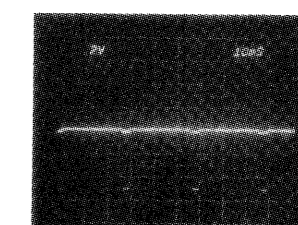

12 IC601 (5)

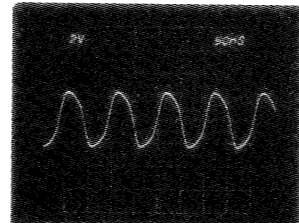

3 IC504 (34, 35)



9 IC504 (60) (TP DREF), IC515 (69) (TP SWP) PLAY MODE

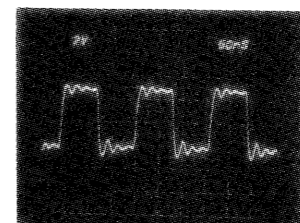

16 IC515 (53)



14 IC515 (69, 72)

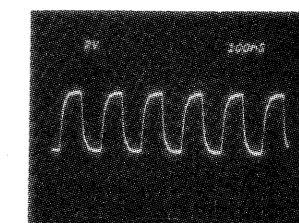

27 IC307 (23) (TP310)

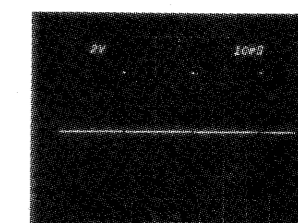

13 IC601 (8)

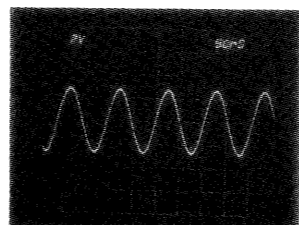

4 IC504 (35)

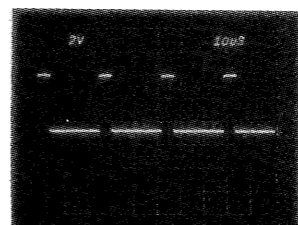

11 IC504 (66)

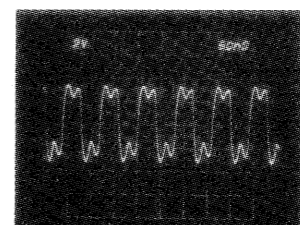

17 IC515 (69)

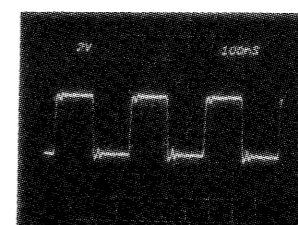

22 IC515 (73, 75)

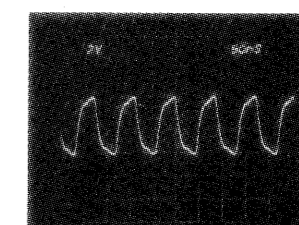

18 IC302 (2) (TP319)

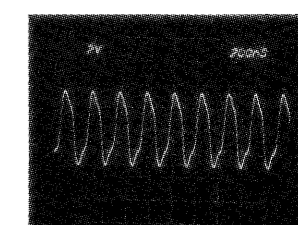

14 IC601 (60)

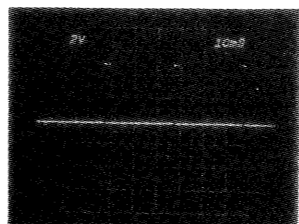

5 IC504 (37, 40, 41)

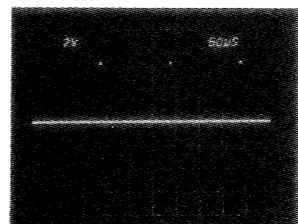

11 IC504 (69) PLAY MODE

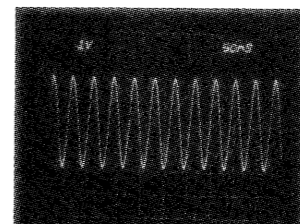

17 IC515 (63) (used on TY-7551)

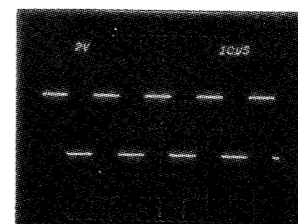

24 IC302 (20) (TP324)

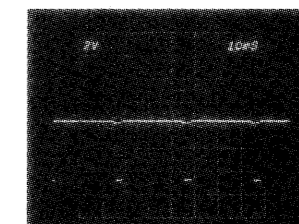

20 IC302 (8) (TP320)

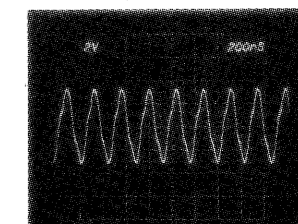

15 IC601 (61)

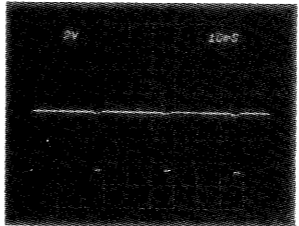

6 IC504 (38, 39, 42, 43) IC503 (6), IC504 (59) (TP DPG) PLAY MODE

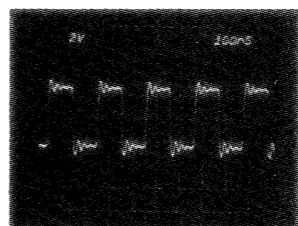

12 IC515 (10)

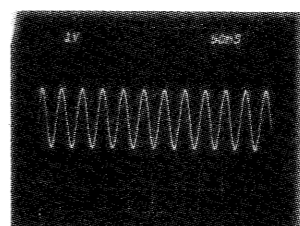

17 IC515 (64) (used on TY-7551)

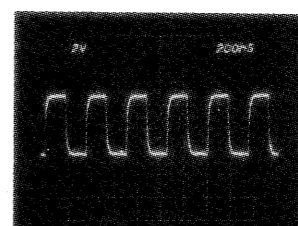

24 IC302 (21) (TP325)

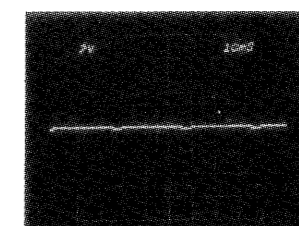

19 IC302 (9) (TP321)

5-8. PIN DESCRIPTION

● IC504 CXP80524-022Q

Pin No.	Symbol	I/O	Pin Description
1	DMCRQ	O	Serial communication demand signal to CXP5024 ("L"→ through communication)
2	VCORST	O	RX VCO enable signal ("H"→ enable)
3	XSTBY	O	CXA8006/CXA1127 standby signal ("L"→ standby state)
4	XDRMON	O	Drum motor ON/OFF signal ("H"→ motor stop)
5	XCAPON	O	Capstan motor ON/OFF signal ("H"→ motor stop)
6	CAPDIR	O	Capstan motor rotation direction control signal ("H"→ forward drive rotation)
7	XLWR	O	Data-bus (MSM6338) write demand signal ("L"→ LD0 to 3output pin)
8	XLRD	O	Date-bus (MSM6338) read demand signal ("L"→ LD0 to 3input pin)
9	LAD1	O	Address-bus (MSM6338)
10	LAD0	O	Address-bus (MSM6338)
11	REI	I	Rotary encoder input
12	REM	I	Rotary encoder input
13	REO	I	Rotary encoder input
14	RELD	I	Load detection signal ("H"→ load completion)
15	REULD	I	Un-load detection ("H"→ un-load completion)
16	XRECINH	I	Record prohibition detection ("L"→ record prohibition state)
17	XCSALK	I	Cassette compartment lock detection ("L"→ cassette compartment lock state)
18	CASIN	I	Cassette insert detection ("H"→ cassette insert state)
19	LD3	I/O	Data-bus (MSM6338)
20	LD2	I/O	Data-bus (MSM6338)
21	LD1	I/O	Data-bus (MSM6338)
22	LD0	I/O	Data-bus (MSM6338)
23	AC/DC	I	AC/DC power source detection ("L"→ AC power source)
24	XDEW	I	DEW detection ("L"→ dew state)
25	WAKEUP	O	CXP5024 stop mode set up ("L"→ stop mode)
26	DDCONT	O	DC/DC converter ON/OFF signal ("H"→ DC/DC converter ON)
27	CTRMA	O	Control motor control signal
28	CTRMB	O	Control motor control signal
29	ENLON	O	LED ON/OFF signal for tape-top/end detection ("H"→ LED ON)
30	PLGON	O	Plunger ON/OFF signal ("H"→ plunger ON)
31	MP	I	Connect to the GND.
32	XRST	I	CXP80524 reset signal ("L"→ reset)
33	V _{SS}	—	Connect to the GND.
34	XTAL	O	Crystal vibration (9.408MHz) output
35	EXTAL	I	Crystal vibration (9.408MHz) input
36	MUTM	I	Mute output detection ("H"→ mute ON)
37	SI	I	Key/Display I/O serial data input
38	SO	O	Key/Display I/O serial data output
39	XSCK	O	Key/Display I/O clock
40	SBSY	I	Sub-code I/O communication demand signal (Communication start on down edge.)
41	SBSI	I	Sub-code I/O serial data input
42	SBSO	O	Sub-code I/O serial data output
43	EXCK	O	Sub-code I/O clock
44	AV _{SS}	—	Connect to the GND.
45	AV _{REF}	—	Standard voltage power source
46	AV _{DD}	—	

Pin No.	Symbol	I/O	Pin Description
47	SWPADJ	AIN	Voltage input for switching pulse delay adjustment
48	RFENV	AIN	Envelope detection input of head playback signal
49	XEJECT	I	EJECT key input ("L"→ EJECT key ON)
50	XPOWER	I	POWER key input ("L"→ POWER key ON)
51	XTTOP	I	Take-up side (on forward) sensor detection input ("L"→ tape top)
52	XTEND	I	Supply side (on forward) sensor detection input ("L"→ tape end)
53	BATTERY	AIN	Battery voltage input
54	ATFPLT	AIN	ATF pilot detection signal
55	TRLFG	I	Reel FG input of take-up side (24tooth output per 1 rotary)
56	SRLFG	I	Reel FG input of supply side (24tooth output per 1 rotary)
57	CAPFG	I	Capstan FG input (360tooth output per 1 rotary)
58	DRMFG	I	Drum FG input (24tooth output per 1 rotary)
59	DRMPG	I	Drum PG input
60	DREF	I	Drum standard signal (LP mode → 16.7Hz SP mode → 33.3Hz)
61	MCLK	I	Channel clock (9.408MHz)
62	RFDT	I	Head playback data
63	SWP	O	Switching pulse ("L"→ A channel head select)
64	DRMPWM	O	PWM output for drum motor control (Carrier frequency=36.75kHz)
65	CAPPWM	O	PWM output for capstan motor control (Carrier frequency=36.75kHz)
66	ATFPWM	O	PWM output for ATF gain control amplifier control (Carrier frequency=36.75kHz)
67	ALARM	O	Not used on this set.
68	MLE	O	Serial data take-in signal (Take-in on up edge.)
69	SYMN	I	C1 syndrome pulse input
70	XTEST	I	Test/Standard mode set up ("L"→ test mode on POWER ON.)
71	XNMI	—	Connect to the +B.
72	V _{DD}	—	Connect to the +B.
73	V _{SS}	—	Connect to the GND.
74	N.C.	—	Connect to the +B.
75	ATSY	O	After record timing signal
76	DMUTE	O	A/D and D/A data mute signal ("H"→ mute)
77	SEARCH	O	Search and after record mode set up ("H"→ search and after record)
78	MODE	O	CXA1364 mode set up
79	XLMUTE	O	Line out mute signal ("H"→ mute)
80	ADCON	O	A/D converter ON/OFF signal ("L" → action)

● IC515 CXD2601AQ

Pin No.	Symbol	I/O	Pin Description
1	A08	I/O	RAM address
2	A09	I/O	RAM address
3	V _{DD}	—	Connect to the +5V.
4	A10	I/O	RAM address
5	A11	I/O	RAM address
6	A12	I/O	RAM address
7	A13	I/O	RAM address
8	A14	I/O	RAM address
9	XWE	O	RAM write enable signal
10	XOE	O	RAM output enable signal
11	XEAN	O	Bus wedge enable signal for external addressing. Not used on this set.
12	TST1	I	Test pin (Normally, "L")
13	XT10	O	Crystal vibrator connect pin (18.816MHz)
14	XT11	I	Crystal vibrator connect pin (18.816MHz)
15	V _{SS}	—	Connect to the GND.
16	XRST	I	Reset pin (Normally, "H")
17	CLKO	I/O	Clock output pin (18.816MHz). Not used on this set.
18	XCST	I/O	CLKO divided timing signal for SYCK (Internal system CLK) creation. Not used on this set.
19	ATSY	I	ATF sync signal input pin
20	MCLK	O	Clock output pin (9.408MHz). Not used on this set.
21	DREF	O	Drum servo standard signal (Normal : 50/3 to 200/3Hz Search : 16kHz)
22	SBPM	O	Discrimination signal for receive or reject to clock for sub-code I/O. ("L" : receive "H" : reject). Not used on this set.
23	EXCK	I	Data transmission clock for sub-code I/O
24	SDSI	I	Sub-code serial data input
25	SDSO	O	Sub-code serial data output
26	SBSY	O	Sync signal for sub-code I/O
27	COPY	O	Copy information output. Not used on this set.
28	EMP	O	Emphasis information output. Not used on this set.
29	MUTE	I	Mute pin
30	MUTM	O	Mute discrimination signal ("H" : mute)
31	UNLK	O	RX PLL lock discrimination signal ("H" : PLL lock)
32	ERMN	O	RF existence detection ("H" : RF exist On record : "L")
33	SYMN	O	RF correspondence C1 check result ("H" : OK)
34	CHER	I	Discrimination signal of once or twice for C2. (C2 → C1 → C2 or C1 → C2) ("H" : once "L" : twice)
35	PLCK	I/O	RF PLL clock output
36	TST2	I	Test pin (Normally, "L")
37	RFDT	I	RF signal input pin
38	XCS	I	Sub-code I/O chip select ("L" : select)
39	SWP	I	RF switching pulse ("L" : A channel "H" : B channel)
40	V _{SS}	—	Connect to the GND.
41	PIPC	O	Record data PILOT/PCM discrimination signal ("H" : PILOT On playback "L")
42	REPB	O	Record/Playback select signal ("H" : record)
43	REDT	O	Record signal output ("L" : playback)
44	TST4	I	Test pin (Normally, "L")
45	TST3	O	PD output of RX • APLL (Comparator output pin)

Pin No.	Symbol	I/O	Pin Description
46	TST5	I	Oscillation cell amplifier input pin of RX • APLL
47	TST6	O	Oscillation cell amplifier reverse output pin of RX • APLL
48	PLCO	I	Outside addition VCO clock input pin of RX • APLL
49	PLVR	O	On comparator outside addition comparison signal output of RX • APLL (Vin). Not used on this set.
50	PLRF	O	On comparator outside addition comparison signal output of RX • APLL (Rin). Not used on this set.
51	MSSL	I	Master/Sleave set up (“H” : master “L” : sleeve)
52	RX	I	Digital input
53	V _{DD}	—	Connect to the +5V.
54	TX	O	Digital output
55	AUDR	I	Audio mode/Data recorder mode set up (“H” : audio “L” : data)
56	EXSY	I/O	Synchro signal for perfect copy 25/3 to 100/3Hz
57	EXSN	I/O	Synchro signal for perfect copy 25/3 to 100/3Hz (Normally, connect to the EXSY)
58	F128	I/O	$128 \times f_s \text{CK}(\text{Normal}) / 256 \times f_s \text{CK}(\times 2)$
59	F256	O	$256 \times f_s \text{CK}(\text{Normal}) / 256 \times f_s \text{CK}(\times 2)$
60	F512	O	$512 \times f_s \text{CK}(\text{Normal}) / 512 \times f_s \text{CK}(\times 2)$. Not used on this set.
61	ADLF	I	Descrimination signal of first LSB or first MSB for ADDT serial data. (“H” : first LSB)
62	DALF	I	Descrimination signal of first LSB or first MSB for DADT serial data. (“H” : first LSB)
63	XT2O	O	Crystal vibrator connect pin (22.5792MHz)
64	XT2I	I	Crystal vibrator connect pin (22.5792MHz)
65	V _{SS}	—	Connect to the GND.
66	XT3O	O	Crystal vibrator connect pin (B mode : 24.576MHz)
67	XT3I	I	Crystal vibrator connect pin (B mode : 24.576MHz)
68	FSEN	I	I/O select of F128, BCK and LRCK (“H” : output)
69	LR03	O	Reverse of LR02
70	LR02	O	16BCK delayed signal of LRCK. Not used on this set.
71	LR01	O	15BCK delayed signal of LRCK. Not used on this set.
72	LRCK	I/O	$f_s(\text{Normal}) / 2 \times f_s(\times 2)$ (“L” : L channel “H” : R channel)
73	WCK	I/O	$2 \times f_s(\text{Normal}) / 4 \times f_s(\times 2)$
74	XBCK	O	Reverse of BCK. Not used on this set.
75	BCK	I/O	$64 \times f_s(\text{Normal}) / 128 \times f_s(\times 2)$
76	ADDT	I	Serial AD data
77	DADT	O	Serial DA data
78	DADO	I	(DA) data input pin for digital output (Normally, connect to the DADT)
79	ADDI	O	(AD) data output pin for digital input (Normally, connect to the ADDN)
80	ADDN	I	(DA) data input pin for digital input
81	ERRI	I	V-FLAG information input for digital output (Normally, connect to the ERRF)
82	ERRF	O	Description signal of interpolation or not for DADT data. (“H” : interpolation data)
83	MNTG	O	Error correction situation monitor trigger
84	D7	I/O	RAM data-bus
85	D6	I/O	RAM data-bus
86	D5	I/O	RAM data-bus
87	D4	I/O	RAM data-bus
88	D3	I/O	RAM data-bus
89	D2	I/O	RAM data-bus
90	V _{SS}	—	Connect to the GND.
91	D1	I/O	RAM data-bus

Pin No.	Symbol	I/O	Pin Description
92	D0	I/O	RAM data-bus
93	A00	I/O	RAM address
94	A01	I/O	RAM address
95	A02	I/O	RAM address
96	A03	I/O	RAM address
97	A04	I/O	RAM address
98	A05	I/O	RAM address
99	A06	I/O	RAM address
100	A07	I/O	RAM address

● IC307 CS5326-KP

Pin No.	Symbol	I/O	Pin Description
1	AGND	—	Analog ground pin
2	AINL	I	L channel analog input pin. Full-scale of input is $\pm 3.6V$.
3	ZEROL	I	L channel zero level input pin. Normally, input voltage sets to zero level and carribration the L channel offset. Normally, connect the analog ground pin.
4	VA+	—	Analog plus power source, +5V.
5	VA-	—	Analog minus power source, -5V.
6	APD	I	Analog power down pin. In case of "H", set the power down mode. Normally, connect the DPD pin. And this pin could be used synchronized plural AK5326 sampling together DPD pin.
7	ACAL	I	Analog carribration pin. Normally, connect the DCAL pin. In case of "H", L/ \bar{R} input channel is connect the internal each zero level input pin (ZEROL, ZEROR). In case of "L", connect the analog input pin (AINL, AINR).
8	NC	—	No connect pin
9	DCAL	O	Analog carribration pin. Normally, use on as input signal of ACAL pin. If and when one input the power down signal to breaking DPD pin, at once up and later 4096L/ \bar{R} cycle (In case of 6.144MHz, about 85msec) was changed "L" and display finish of offset carribration. And, in case of system carribration use on external MUX channel select signal.
10	DPD	I	Digital power down pin. In case of "H", set the power down mode.
11	TST1	I	Test pin Connect to the DGND pin.
12	TST2	I	
13	TST3	I	
14	L/ \bar{R}	I	Input channel select pin. To select the channel of output data from SDATA pin. To output the L channel data in case of "H" and R channel data in case of "L".
15	SCLK	I	Serial data output clock pin. On clock up change 1 bit for output data. Normally, to input the 4 divided for master clock.
16	SDATA	O	Serial data output pin. Data is 2 ⁿ complement and output in order from MSB. To output the 1bit data for rise SCLK. While output "L" for SCLK input of more than 17.
17	VD1+	—	Digital plus power source, +5V.
18	VD2+	—	
19	DGND	—	Digital ground pin
20	DCLKA	I	Digital system clock pin. Connect the ACLKA pin.
21	NC	—	No connect pin. This pin is use on open.
22	ACLKA	O	Analog system clock pin. Connect the DCLKA pin. To output the 2 divided clock for master clock.
23	CLKIN	I	Master clock pin. Sampling rate of $\Delta \cdot \Sigma$ modulator is 2 divided for this clock. Output word rate per cannel is 48kHz in case of 6.144MHz clock.
24	LGND	—	Digital ground pin
25	VL++	—	Digital power source, +5V.
26	ZEROR	I	R channel zero level input pin. Normally, input voltage sets to zero level and carribration the R channel offset. Normally, connect the analog ground pin.
27	AINR	I	R channel analog input pin. Full-scale of input is $\pm 3.6V$.
28	VREF	O	Standard power source, -3.6V

• IC601 CXP5024H-114Q

Pin No.	Symbol	I/O	Pin Description
1	PY0	O	EL pin
2	PY1	O	
3	INT2/PY2	I	
4	EC/PY3	I	Serial I/O request pin
5	SC/PX0	I/O	Serial • Clock
6	SOB/PX1	I/O	Serial • out
7	SOA/PX2	I/O	Not used on this set.
8	SI/PX3	I	Serial • in
9	PD0	I/O	Digital/Analog select switch
10	PD1	I/O	LP/SP select switch
11	PD2	I/O	
12	PD3	I/O	Counter • mode • key
13	PC0	I/O	Counter • reset • key
14	PC1	I/O	Start ID • mode • key
15	PC2	I/O	Start ID • set • key
16	PC3	I/O	Back • light • key
17	PB0	I/O	REC key
18	PB1	I/O	PAUSE key
19	PB2	I/O	AMS (-) key
20	PB3	I/O	AMS (+) key
21	PA0	I/O	REW key
22	PA1	I/O	STOP key
23	PA2	I/O	PLAY key
24	PA3	I/O	FF key
25	V _{SS}	-	Connect to the GND.
26	(V _{DD})	O	Connect to the +5V.
27	PE3/SEG23	O	Segment 23
28	PE2/SEG22	O	Segment 22
29	PE1/SEG21	O	Segment 21
30	PE0/SEG20	O	Segment 20
31	PF3/SEG19	O	Segment 19
32	PF2/SEG18	O	Segment 18
33	PF1/SEG17	O	Segment 17
34	PF0/SEG16	O	Segment 16
35	SEG15	O	Segment 15
36	SEG14	O	Segment 14
37	SEG13	O	Segment 13
38	SEG12	O	Segment 12
39	SEG11	O	Segment 11
40	SEG10	O	Segment 10
41	SEG9	O	Segment 9
42	SEG8	O	Segment 8
43	SEG7	O	Segment 7
44	SEG6	O	Segment 6
45	SEG5	O	Segment 5
46	SEG4	O	Segment 4
47	SEG3	O	Segment 3

Pin No.	Symbol	I/O	Pin Description
48	SEG2	O	Segment 2
49	SEG1	O	Segment 1
50	SEG0	O	Segment 0
51	COM3	O	Common 3
52	COM2	O	Common 2
53	COM1	O	Common 1
54	COM0	O	Common 0
55	VLC1	—	LCD power source
56	VLC2	—	LCD power source
57	VLC3	—	LCD power source
58	V _{DD}	—	Power source voltage
59	VL	O	Cut off
60	XTAL	O	Clock output
61	EXTAL	I	Clock input
62	RST	I/O	Reset pin
63	WP	I	Wake up pin
64	INT1	I	Outside wedge (for remote commander)

REVISED

6-2. CHASSIS ASSEMBLY

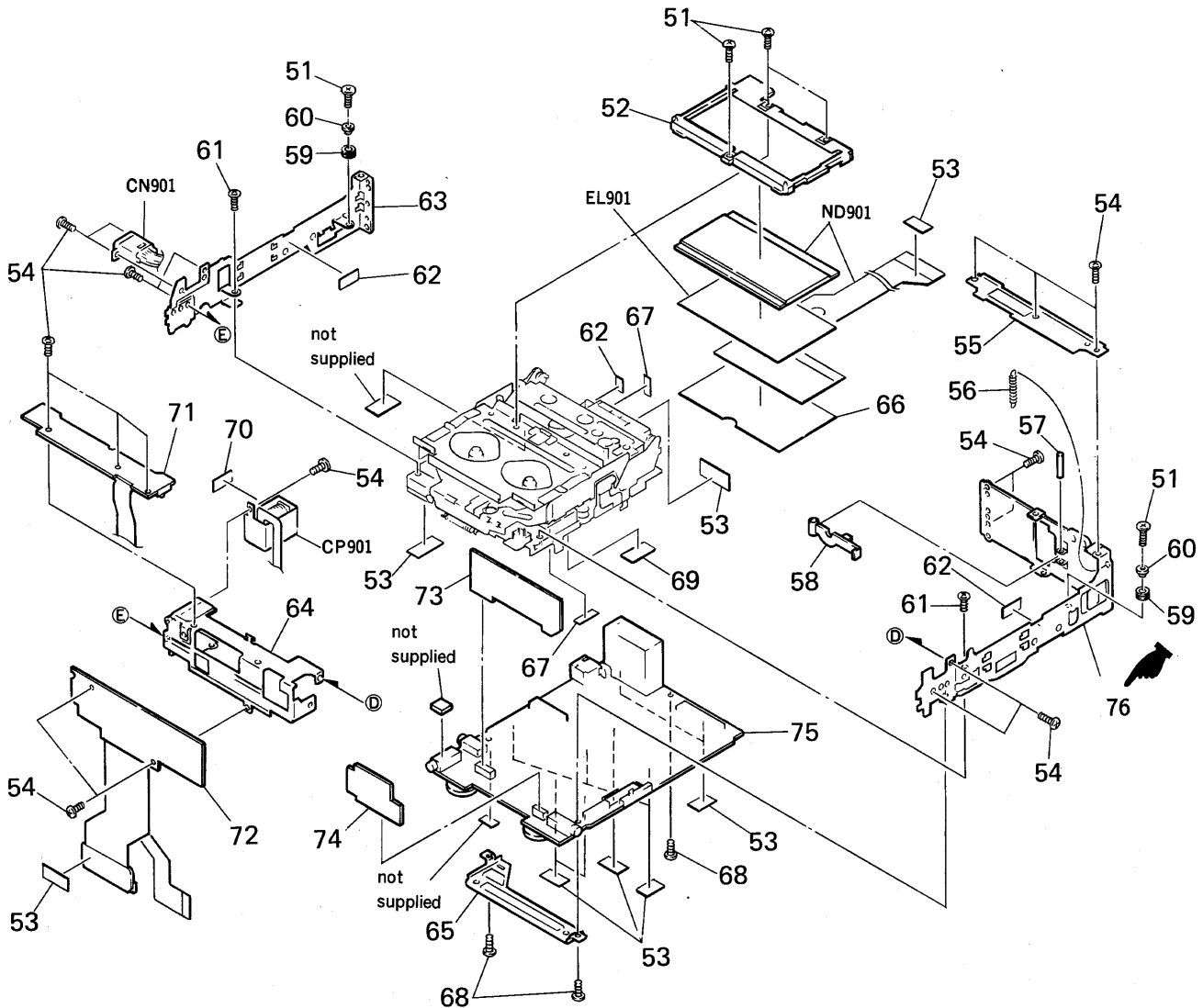

Ref.No	Part No.	Description	Remarks
51	3-704-197-31	SCREW (M1.4X3.0), LOCKING	
52	3-361-133-01	BRACKET, LCD	
53	3-831-441-11	CUSHION (B)	
54	3-704-197-01	SCREW (M1.4X1.6), LOCKING	
55	*3-361-140-01	REINFORCEMENT, BATT FITTING	
56	3-308-704-00	SPRING, TENSION (REC LEVER RETURN)	
57	3-703-575-11	PIN (DIA. 1.2X8), PARALLEL	
58	3-361-156-01	CLAW, BATT LOCK	
59	3-362-469-01	CUSHION, MD FITTING	
60	3-362-468-01	SPACER (MD FITTING)	
61	3-363-716-01	SCREW (M1.4X1.6)	
62	*3-310-165-00	SPACER	
63	*3-361-137-01	CHASSIS (L)	
64	*3-361-139-01	CHASSIS (FRONT)	
65	*3-361-141-01	BRACKET, LOWER PANEL	

Ref.No	Part No.	Description	Remarks
66	3-363-576-01	CUSHION (EL)	
67	3-570-611-00	SHEET, PROTECTION, LID	
68	3-704-244-31	SCREW (P1.7X2.5)	
69	*3-334-575-01	SPACER	
70	9-911-838-XX	PACKING, KNOB	
71	1-572-408-11	SWITCH, ENCAPSULATED	
72	A-3015-915-A	DR BOARD, COMPLETE	
73	*1-635-763-11	ADA BOARD	
74	*1-635-764-11	LINE AMP BOARD	
75	A-3015-913-A	MAIN BOARD, COMPLETE	
CN901	1-575-917-11	CABLE (WITH CONNECTOR) (REMOTE DIGITAL I/O)	
CP901	1-466-378-11	INVERTER UNIT	
EL901	1-519-621-11	ELECTRIC LUMINESCENCE	
ND901	1-550-598-11	DISPLAY PANEL, LIQUID CRYSTAL	

76 X-3366-416-1 CHASSIS(R) ASSY

6-3. CASSETTE HOLDER ASSEMBLY
(MT-D3-47)

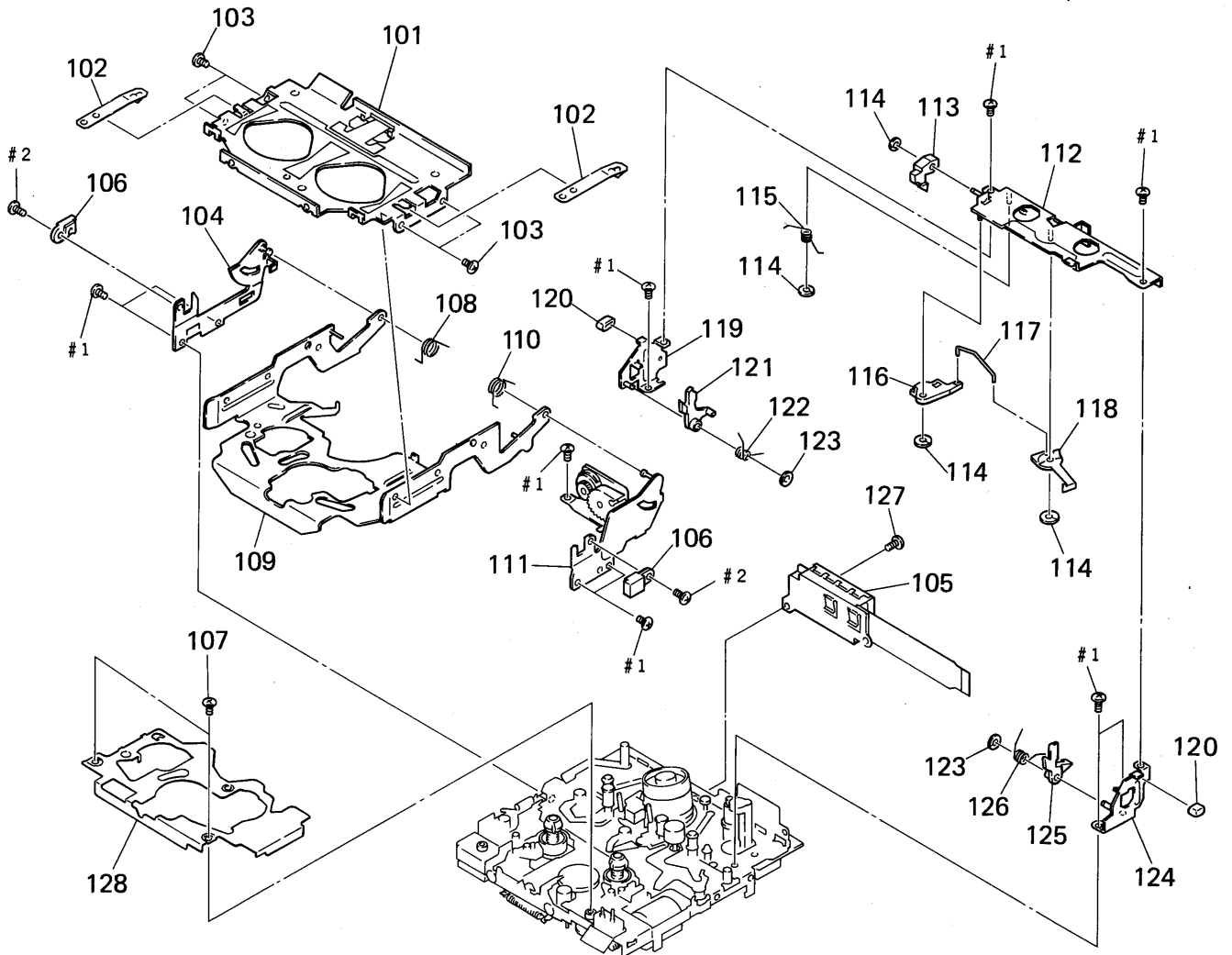

Ref.No	Part No.	Description	Remarks	Ref.No	Part No.	Description	Remarks
101	X-3362-185-1	HOLDER (UPPER) ASSY		115	3-363-266-01	SPRING, TORSION	
102	X-3344-982-1	SPRING (HOLDER B) ASSY, LEAF		116	*3-363-261-01	LEVER (B)	
103	3-349-825-21	SCREW		117	3-363-443-01	LINK	
104	X-3344-980-1	BRACKET (CLA) ASSY		118	X-3362-183-1	WIPER ASSY	
105	1-466-369-11	RF MODULE		119	X-3344-978-1	BRACKET (CLB) ASSY	
106	3-363-454-01	HOLDER (ES)		120	3-363-279-01	CUSHION (HOLDER)	
107	3-363-220-21	SCREW (M1.4X1.8)		121	3-361-174-01	LEVER (LID L)	
108	3-363-270-01	SPRING, TORSION		122	3-363-267-01	SPRING, TORSION	
109	X-3344-983-1	HOLDER (CASSETTE) ASSY		123	3-321-813-01	WASHER, COTTER POLYETHYLENE (1.5-4.0) T=0.25	
110	3-363-269-01	SPRING, TORSION		124	X-3344-979-1	BRACKET (CRB) ASSY	
111	X-3362-186-1	DAMPER (CRA) ASSY		125	3-361-173-01	LEVER (LID R)	
112	X-3362-184-1	COVER (TAPE PASS) ASSY		126	3-363-268-01	SPRING, TORSION	
113	*3-363-260-01	LEVER (A)		127	3-349-825-01	SCREW	
114	3-315-384-11	WASHER, STOPPER (1.2-2.5) T=0.25		128	3-363-286-01	COVER (MD)	

6-4. MD ASSEMBLY 1
(MT-D3-47)

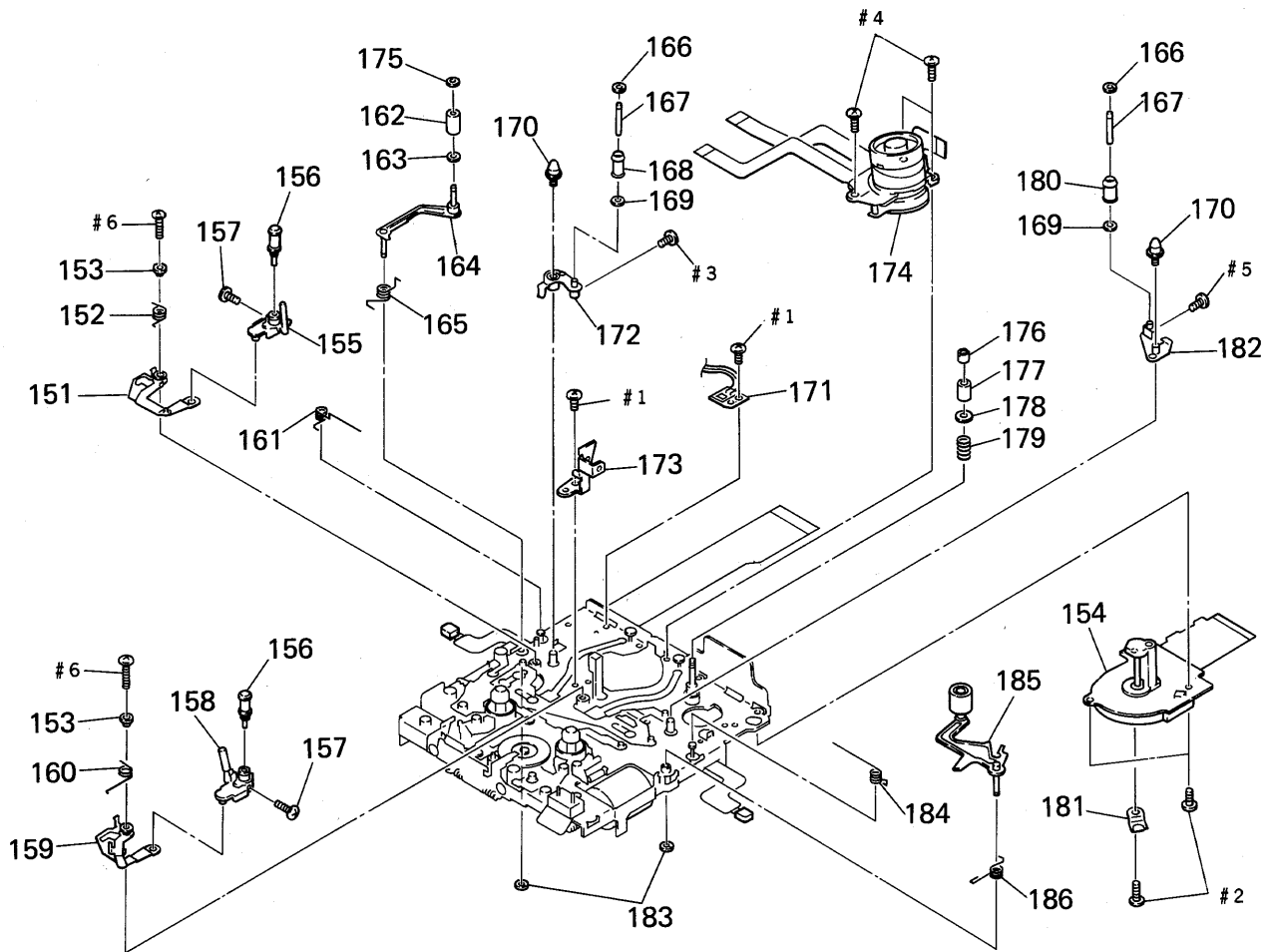

Ref.No	Part No.	Description	Remarks	Ref.No	Part No.	Description	Remarks
151	X-3344-945-1	LEVER (LOADING SA) ASSY		169	3-361-163-41	WASHER (1.3-3.2) T=0.19	
152	3-360-897-01	SPRING, TORSION		170	3-360-817-01	SHAFT (CASSETTE)	
153	3-354-247-01	SHAFT (LOADING B)		171	1-808-281-41	SENSOR (DEW)	
154	8-835-412-01	MOTOR, DC SCR-0101A		172	X-3344-953-1	LEVER (SF) ASSY	
155	X-3344-968-1	GUIDE BLOCK (S) ASSY, SLANT		173	3-360-862-01	REINFORCEMENT (LED)	
156	X-3344-963-1	GUIDE (DIA. 4) ASSY, ROLLER		174	8-848-536-11	DRUM ASSY (DOU-12A)	
157	3-728-290-01	SCREW (M1.2)		175	3-321-393-11	STOP RING	
158	X-3344-969-1	GUIDE BLOCK (T) ASSY, SLANT		176	3-337-605-01	NUT, ADJUSTMENT	
159	X-3344-943-1	LEVER (LOADING TA) ASSY		177	3-366-697-21	GUIDE (GA), FIXED	
160	3-360-895-01	SPRING, TORSION		178	3-337-677-01	FLANGE	
161	3-361-106-01	SPRING, TORSION		179	3-573-470-00	SPRING, COMPRESSION	
162	3-360-866-01	ROLLER (TENSION REGULATOR)		180	3-360-863-01	ROLLER (A), GUIDE	
163	3-361-163-31	WASHER (1.3-3.2) T=0.13		181	3-363-224-01	REINFORCEMENT (CAPSTAN MOTOR)	
164	X-3344-950-1	LEVER(TENSION REGULATOR A) ASSY		182	X-3344-952-1	LEVER (TF) ASSY	
165	3-361-118-01	SPRING, TORSION		183	3-315-384-11	WASHER, STOPPER (1.2-2.5) T=0.25	
166	3-361-162-01	WASHER (0.8-2.2) T=0.25		184	3-361-105-01	SPRING, TORSION	
167	3-354-289-01	SHAFT (TAPE GUIDE)		185	X-3362-201-1	ARM ASSY, PINCH ROLLER	
168	3-360-864-01	ROLLER (B), GUIDE		186	3-361-115-01	SPRING, TORSION	

ADA APS DR

SECTION 7
ELECTRICAL PARTS LIST

NOTE:

- Due to standardization, replacements in the parts list may be different from the parts specified in the diagrams or the components used on the set.
- Items marked "*" are not stocked since they are seldom required for routine service. Some delay should be anticipated when ordering these items.
- If there are two or more same circuits in a set such as a stereophonic machine, only typical circuit parts may be indicated and capacitors and resistors in other same circuits may be omitted.

CAPACITORS:

MF: μF , PF: $\mu\mu F$.

RESISTORS

- All resistors are in ohms.
- F: nonflammable

COILS

- MMH: mH, UH: μH

SEMICONDUCTORS

In each case, U: μ , for example:
UA....: μA ..., UPA....: μPA ...,
UPC....: μPC , UPD....: μPD ...

- Screw (#mark) list is given in the last of this parts list.

The components identified by mark Δ or dotted line with mark Δ are critical for safety. Replace only with part number specified.

Les composants identifiés par une marque Δ sont critiques pour la sécurité. Ne les remplacer que par une pièce portant le numéro spécifié.

Ref.No	Part No.	Description	Remark
	*1-635-763-11	ADA BOARD *****	
<u>CAPACITOR</u>			
C117	1-164-480-11	CERAMIC CHIP	0.01MF 5% 50V
C217	1-164-480-11	CERAMIC CHIP	0.01MF 5% 50V
C312	1-135-157-21	TANTAL. CHIP	10MF 10% 6.3V
C313	1-164-004-11	CERAMIC CHIP	0.1MF 10% 25V
C314	1-164-004-11	CERAMIC CHIP	0.1MF 10% 25V
C315	1-164-004-11	CERAMIC CHIP	0.1MF 10% 25V
C316	1-164-004-11	CERAMIC CHIP	0.1MF 10% 25V
C317	1-135-157-21	TANTAL. CHIP	10MF 10% 6.3V
C318	1-135-157-21	TANTAL. CHIP	10MF 10% 6.3V
C319	1-135-157-21	TANTAL. CHIP	10MF 10% 6.3V
C320	1-164-004-11	CERAMIC CHIP	0.1MF 10% 25V
C321	1-135-180-21	TANTAL. CHIP	3.3MF 10% 6.3V
C322	1-135-180-21	TANTAL. CHIP	3.3MF 10% 6.3V
C323	1-135-157-21	TANTAL. CHIP	10MF 10% 6.3V
C324	1-135-157-21	TANTAL. CHIP	10MF 10% 6.3V
C325	1-135-180-21	TANTAL. CHIP	3.3MF 10% 6.3V
C326	1-135-180-21	TANTAL. CHIP	3.3MF 10% 6.3V
C327	1-164-234-11	CERAMIC CHIP	1MF 10V
C328	1-164-234-11	CERAMIC CHIP	1MF 10V
<u>CONNECTOR</u>			
CN304	1-568-366-41	CONNECTOR, BOARD TO BOARD 16P	
<u>DIODE</u>			
D302	8-719-400-18	DIODE MA152WK	
D303	8-719-104-34	DIODE 1S2836	
<u>IC</u>			
IC307	8-759-999-09	IC CS5326-KP	
IC308	8-759-999-56	IC PCM1700U-J	
<u>COIL</u>			
L301	1-412-137-11	INDUCTOR 10UH	
<u>RESISTOR</u>			
R125	1-216-612-11	METAL CHIP 24	0.50% 1/10W
R126	1-216-613-11	METAL CHIP 27	0.50% 1/10W
R225	1-216-612-11	METAL CHIP 24	0.50% 1/10W
R226	1-216-613-11	METAL CHIP 27	0.50% 1/10W
R306	1-216-150-00	METAL GLAZE 10	5% 1/8W

Ref.No	Part No.	Description	Remark
	*1-637-533-11	APS BOARD *****	
<u>CAPACITOR</u>			
C801	1-135-161-21	TANTAL. CHIP	22MF 10% 10V
C802	1-164-004-11	CERAMIC CHIP	0.1MF 10% 25V
<u>CONNECTOR</u>			
CN801	*1-566-181-11	PIN, CONNECTOR (PC BOARD) 2P	
<u>DIODE</u>			
D801	8-719-800-76	DIODE 1SS226	
<u>JACK</u>			
J801	1-507-933-11	JACK (MIC DC OUT)	
<u>TRANSISTOR</u>			
Q801	8-729-141-48	TRANSISTOR 2SB624-BV345	
<u>RESISTOR</u>			
R801	1-216-832-11	METAL GLAZE 8.2K	5% 1/16W
R802	1-216-830-11	METAL GLAZE 5.6K	5% 1/16W
R803	1-216-021-00	METAL GLAZE 68	5% 1/10W
R804	1-216-021-00	METAL GLAZE 68	5% 1/10W
R805	1-216-025-00	METAL GLAZE 100	5% 1/10W

	A-3015-915-A	DR BOARD, COMPLETE *****	
	3-831-441-11	CUSHION (B)	
<u>CAPACITOR</u>			
C601	1-164-156-11	CERAMIC CHIP	0.1MF 25V
C602	1-164-156-11	CERAMIC CHIP	0.1MF 25V
C603	1-162-955-11	CERAMIC CHIP	150PF 5% 50V
C604	1-164-156-11	CERAMIC CHIP	0.1MF 25V
C605	1-135-167-21	TANTAL. CHIP	68MF 20% 6.3V
C606	1-164-156-11	CERAMIC CHIP	0.1MF 25V
<u>CONNECTOR</u>			
CN601	*1-566-935-11	HOUSING, CONNECTOR 3P	
CN602	*1-569-352-11	HOUSING, CONNECTOR 10P	
<u>DIODE</u>			
D601	8-719-940-28	DIODE DSD010	
<u>IC</u>			
IC601	8-752-814-60	IC CXP5024H-114Q	

DR

LINE AMP

MAIN

Ref.No	Part No.	Description	Remark
<u>TRANSISTOR</u>			
Q603	8-729-901-46	TRANSISTOR DTA114YK	
<u>RESISTOR</u>			
R601	1-216-827-11	METAL GLAZE 3.3K 5%	1/16W
R602	1-216-841-11	METAL GLAZE 47K 5%	1/16W
R603	1-216-841-11	METAL GLAZE 47K 5%	1/16W
R604	1-216-841-11	METAL GLAZE 47K 5%	1/16W
R605	1-216-841-11	METAL GLAZE 47K 5%	1/16W
R606	1-216-841-11	METAL GLAZE 47K 5%	1/16W
R607	1-216-841-11	METAL GLAZE 47K 5%	1/16W
R608	1-216-841-11	METAL GLAZE 47K 5%	1/16W
R609	1-216-841-11	METAL GLAZE 47K 5%	1/16W
R612	1-216-811-11	METAL GLAZE 150 5%	1/16W
R613	1-216-811-11	METAL GLAZE 150 5%	1/16W
R614	1-216-841-11	METAL GLAZE 47K 5%	1/16W
<u>NETWORK RESISTOR</u>			
RB601	1-236-500-11	RES, NETWORK (10KX3)	
RB602	1-236-501-21	RES, NETWORK (47KX3)	
RB603	1-236-501-21	RES, NETWORK (47KX3)	
<u>SWITCH</u>			
S601	1-572-409-11	SWITCH, SLIDE (POWER)	
S602	1-571-533-31	SWITCH, KEY BOARD (LIGHT)	
S603	1-571-533-31	SWITCH, KEY BOARD(AMS<<<)	
S604	1-571-533-31	SWITCH, KEY BOARD(AMS>>>)	
S605	1-571-533-31	SWITCH, KEY BOARD (START ID ENTER)	
S606	1-571-533-31	SWITCH, KEY BOARD (START ID MODE)	
S607	1-571-533-31	SWITCH, KEY BOARD (COUNTER MODE)	
S608	1-571-533-31	SWITCH, KEY BOARD (COUNTER RESET)	
S609	1-571-275-11	SWITCH, SLIDE (HOLD)	
<u>CRYSTAL</u>			
X601	1-579-063-21	VIBRATOR, CERAMIC (4.19MHz)	

	*1-635-764-11	LINE AMP BOARD	*****
<u>CAPACITOR</u>			
C114	1-135-149-21	TANTAL. CHIP 2.2MF 10%	10V
C115	1-163-111-00	CERAMIC CHIP 56PF 5%	50V
C116	1-135-161-21	TANTAL. CHIP 22MF 10%	10V
C214	1-135-149-21	TANTAL. CHIP 2.2MF 10%	10V
C215	1-163-111-00	CERAMIC CHIP 56PF 5%	50V
C216	1-135-161-21	TANTAL. CHIP 22MF 10%	10V
C310	1-135-149-21	TANTAL. CHIP 2.2MF 10%	10V
C311	1-135-149-21	TANTAL. CHIP 2.2MF 10%	10V
<u>CONNECTOR</u>			
CN303	1-568-347-41	CONNECTOR, BOARD TO BOARD 5P	
<u>IC</u>			
IC305	8-759-981-99	IC RC4560M	
IC306	8-759-981-99	IC RC4560M	
<u>RESISTOR</u>			
R121	1-216-699-11	METAL CHIP 100K 0.50%	1/10W
R122	1-216-653-11	METAL CHIP 1.2K 0.50%	1/10W
R123	1-216-687-11	METAL CHIP 33K 0.50%	1/10W
R124	1-216-675-11	METAL CHIP 10K 0.50%	1/10W
R221	1-216-699-11	METAL CHIP 100K 0.50%	1/10W

Ref.No	Part No.	Description	Remark
R222	1-216-653-11	METAL CHIP 1.2K 0.50%	1/10W
R223	1-216-687-11	METAL CHIP 33K 0.50%	1/10W
R224	1-216-675-11	METAL CHIP 10K 0.50%	1/10W

	A-3015-913-A	MAIN BOARD, COMPLETE	*****
	*3-572-862-00	SPACER	
	3-831-441-11	CUSHION (B)	
<u>CAPACITOR</u>			
C101	1-135-180-21	TANTAL. CHIP 3.3MF 10%	6.3V
C102	1-135-166-21	TANTAL. CHIP 47MF 10%	10V
C103	1-135-157-21	TANTAL. CHIP 10MF 10%	6.3V
C104	1-162-953-11	CERAMIC CHIP 100PF 5%	50V
C105	1-163-017-00	CERAMIC CHIP 0.0047MF 5%	50V
C106	1-163-009-11	CERAMIC CHIP 0.001MF 5%	50V
C107	1-163-022-00	CERAMIC CHIP 0.012MF 5%	50V
C108	1-135-157-21	TANTAL. CHIP 10MF 10%	6.3V
C109	1-135-180-21	TANTAL. CHIP 3.3MF 10%	6.3V
C110	1-135-157-21	TANTAL. CHIP 10MF 10%	6.3V
C111	1-162-953-11	CERAMIC CHIP 100PF 5%	50V
C112	1-124-576-11	ELECT 220MF 20%	4V
C113	1-162-953-11	CERAMIC CHIP 100PF 5%	50V
C201	1-135-180-21	TANTAL. CHIP 3.3MF 10%	6.3V
C202	1-135-166-21	TANTAL. CHIP 47MF 10%	10V
C203	1-135-157-21	TANTAL. CHIP 10MF 10%	6.3V
C204	1-162-953-11	CERAMIC CHIP 100PF 5%	50V
C205	1-163-017-00	CERAMIC CHIP 0.0047MF 5%	50V
C206	1-163-009-11	CERAMIC CHIP 0.001MF 5%	50V
C207	1-163-022-00	CERAMIC CHIP 0.012MF 5%	50V
C208	1-135-157-21	TANTAL. CHIP 10MF 10%	6.3V
C209	1-135-180-21	TANTAL. CHIP 3.3MF 10%	6.3V
C210	1-135-157-21	TANTAL. CHIP 10MF 10%	6.3V
C211	1-162-953-11	CERAMIC CHIP 100PF 5%	50V
C212	1-124-576-11	ELECT 220MF 20%	4V
C213	1-162-953-11	CERAMIC CHIP 100PF 5%	50V
C301	1-135-156-21	TANTAL. CHIP 6.8MF 10%	10V
C302	1-135-156-21	TANTAL. CHIP 6.8MF 10%	10V
C303	1-135-149-21	TANTAL. CHIP 2.2MF 10%	10V
C304	1-135-149-21	TANTAL. CHIP 2.2MF 10%	10V
C305	1-135-149-21	TANTAL. CHIP 2.2MF 10%	10V
C306	1-135-180-21	TANTAL. CHIP 3.3MF 10%	6.3V
C307	1-135-149-21	TANTAL. CHIP 2.2MF 10%	10V
C308	1-135-149-21	TANTAL. CHIP 2.2MF 10%	10V
C309	1-135-157-21	TANTAL. CHIP 10MF 10%	6.3V
C329	1-164-156-11	CERAMIC CHIP 0.1MF	25V
C330	1-164-156-11	CERAMIC CHIP 0.1MF	25V
C331	1-164-234-11	CERAMIC CHIP 1MF	10V
C501	1-164-156-11	CERAMIC CHIP 0.1MF	25V
C502	1-164-156-11	CERAMIC CHIP 0.1MF	25V
C503	1-164-156-11	CERAMIC CHIP 0.1MF	25V
C504	1-164-156-11	CERAMIC CHIP 0.1MF	25V
C505	1-135-159-21	TANTAL. CHIP 10MF 10%	20V
C506	1-135-161-21	TANTAL. CHIP 22MF 10%	10V
C507	1-163-986-00	CERAMIC CHIP 0.027MF 10%	25V
C508	1-162-965-11	CERAMIC CHIP 0.0015MF 10%	50V
C509	1-163-986-00	CERAMIC CHIP 0.027MF 10%	25V
C510	1-162-965-11	CERAMIC CHIP 0.0015MF 10%	50V
C511	1-162-970-11	CERAMIC CHIP 0.01MF 5%	25V
C512	1-162-967-11	CERAMIC CHIP 0.0033MF 5%	50V
C513	1-162-967-11	CERAMIC CHIP 0.0033MF 5%	50V
C514	1-162-967-11	CERAMIC CHIP 0.0033MF 5%	50V
C515	1-135-154-21	TANTAL. CHIP 3.3MF 10%	20V

MAIN

Ref.No	Part No.	Description	Remark
C516	1-164-157-11	CERAMIC CHIP	0.068MF 10% 25V
C517	1-164-157-11	CERAMIC CHIP	0.068MF 10% 25V
C518	1-135-166-21	TANTAL. CHIP	47MF 10% 10V
C519	1-135-177-21	TANTAL. CHIP	1MF 10% 20V
C520	1-135-177-21	TANTAL. CHIP	1MF 10% 20V
C521	1-135-177-21	TANTAL. CHIP	1MF 10% 20V
C522	1-135-177-21	TANTAL. CHIP	1MF 10% 20V
C523	1-135-177-21	TANTAL. CHIP	1MF 10% 20V
C524	1-135-177-21	TANTAL. CHIP	1MF 10% 20V
C525	1-164-156-11	CERAMIC CHIP	0.1MF 25V
C526	1-162-968-11	CERAMIC CHIP	0.0047MF 10% 50V
C527	1-162-970-11	CERAMIC CHIP	0.01MF 5% 25V
C528	1-135-157-21	TANTAL. CHIP	10MF 10% 6.3V
C529	1-162-947-11	CERAMIC CHIP	33PF 5% 50V
C530	1-135-161-21	TANTAL. CHIP	22MF 10% 10V
C531	1-162-970-11	CERAMIC CHIP	0.01MF 5% 25V
C532	1-162-970-11	CERAMIC CHIP	0.01MF 5% 25V
C533	1-164-227-11	CERAMIC CHIP	0.022MF 10% 25V
C534	1-164-156-11	CERAMIC CHIP	0.1MF 25V
C535	1-164-156-11	CERAMIC CHIP	0.1MF 25V
C536	1-135-157-21	TANTAL. CHIP	10MF 10% 6.3V
C537	1-162-916-11	CERAMIC CHIP	12PF 5% 50V
C538	1-162-916-11	CERAMIC CHIP	12PF 5% 50V
C539	1-164-156-11	CERAMIC CHIP	0.1MF 25V
C540	1-135-161-21	TANTAL. CHIP	22MF 10% 10V
C541	1-135-161-21	TANTAL. CHIP	22MF 10% 10V
C542	1-164-156-11	CERAMIC CHIP	0.1MF 25V
C543	1-135-159-21	TANTAL. CHIP	10MF 10% 20V
C544	1-135-159-21	TANTAL. CHIP	10MF 10% 20V
C545	1-135-161-21	TANTAL. CHIP	22MF 10% 10V
C546	1-135-166-21	TANTAL. CHIP	47MF 10% 10V
C547	1-162-970-11	CERAMIC CHIP	0.01MF 5% 25V
C548	1-164-156-11	CERAMIC CHIP	0.1MF 25V
C549	1-164-227-11	CERAMIC CHIP	0.022MF 10% 25V
C550	1-135-157-21	TANTAL. CHIP	10MF 10% 6.3V
C551	1-163-989-11	CERAMIC CHIP	0.033MF 10% 25V
C552	1-162-967-11	CERAMIC CHIP	0.0033MF 5% 50V
C553	1-135-157-21	TANTAL. CHIP	10MF 10% 6.3V
C554	1-163-989-11	CERAMIC CHIP	0.033MF 10% 25V
C555	1-162-967-11	CERAMIC CHIP	0.0033MF 5% 50V
C556	1-164-156-11	CERAMIC CHIP	0.1MF 25V
C557	1-135-148-21	TANTAL. CHIP	1.5MF 10% 16V
C558	1-135-157-21	TANTAL. CHIP	10MF 10% 6.3V
C559	1-135-157-21	TANTAL. CHIP	10MF 10% 6.3V
C560	1-164-156-11	CERAMIC CHIP	0.1MF 25V
C561	1-164-156-11	CERAMIC CHIP	0.1MF 25V
C562	1-162-915-11	CERAMIC CHIP	10PF 0.5PF 50V
C563	1-162-915-11	CERAMIC CHIP	10PF 0.5PF 50V
C564	1-162-915-11	CERAMIC CHIP	10PF 0.5PF 50V
C565	1-162-915-11	CERAMIC CHIP	10PF 0.5PF 50V
C566	1-162-915-11	CERAMIC CHIP	10PF 0.5PF 50V
C567	1-162-915-11	CERAMIC CHIP	10PF 0.5PF 50V
C568	1-164-156-11	CERAMIC CHIP	0.1MF 25V
C569	1-162-970-11	CERAMIC CHIP	0.01MF 5% 25V
C570	1-164-156-11	CERAMIC CHIP	0.1MF 25V
C571	1-135-166-21	TANTAL. CHIP	47MF 10% 10V
C572	1-164-156-11	CERAMIC CHIP	0.1MF 25V
C574	1-162-964-11	CERAMIC CHIP	0.001MF 10% 50V
C575	1-164-156-11	CERAMIC CHIP	0.1MF 25V
C576	1-164-156-11	CERAMIC CHIP	0.1MF 25V
C577	1-164-156-11	CERAMIC CHIP	0.1MF 25V
C578	1-135-161-21	TANTAL. CHIP	22MF 10% 10V
C579	1-162-962-11	CERAMIC CHIP	470PF 10% 50V
C580	1-164-004-11	CERAMIC CHIP	0.1MF 10% 25V
C581	1-164-156-11	CERAMIC CHIP	0.1MF 25V

Ref.No	Part No.	Description	Remark
C582	1-135-161-21	TANTAL. CHIP	22MF 10% 10V
C583A	1-135-157-21	TANTAL. CHIP	10MF 10% 6.3V
C583B	1-164-156-11	CERAMIC CHIP	0.1MF 25V
C584	1-164-156-11	CERAMIC CHIP	0.1MF 25V
C585	1-162-970-11	CERAMIC CHIP	0.01MF 5% 25V
C586	1-164-156-11	CERAMIC CHIP	0.1MF 25V
C587	1-164-156-11	CERAMIC CHIP	0.1MF 25V
C590	1-162-915-11	CERAMIC CHIP	10PF 0.5PF 50V
C591	1-135-177-21	TANTAL. CHIP	1MF 10% 20V
C592	1-135-177-21	TANTAL. CHIP	1MF 10% 20V
C593	1-162-970-11	CERAMIC CHIP	0.01MF 5% 25V
C594	1-135-177-21	TANTAL. CHIP	1MF 10% 20V
C595	1-162-917-11	CERAMIC CHIP	15PF 5% 50V
C596	1-164-156-11	CERAMIC CHIP	0.1MF 25V
C597	1-164-156-11	CERAMIC CHIP	0.1MF 25V
C701	1-101-888-11	CERAMIC	68PF 5% 50V
C702	1-164-156-11	CERAMIC CHIP	0.1MF 25V
C703	1-164-156-11	CERAMIC CHIP	0.1MF 25V
C704	1-164-156-11	CERAMIC CHIP	0.1MF 25V

CONNECTOR

CN301	1-568-324-31	CONNECTOR, BOARD TO BOARD 5P
CN302	1-568-334-11	CONNECTOR, BOARD TO BOARD 16P
CN501	1-566-531-11	CONNECTOR, FPC (ZIF) 15P
CN502	1-580-438-21	CONNECTOR, FPC 4P
CN503	1-580-438-21	CONNECTOR, FPC 4P
CN504	1-566-526-11	CONNECTOR, FPC (ZIF) 10P
CN505	*1-565-582-21	PIN, CONNECTOR (PC BOARD) 2P
CN506	1-569-531-11	HOUSING, CONNECTOR 20P
CN508	1-566-528-21	CONNECTOR, FPC (ZIF) 12P
CN509	*1-565-582-11	PIN, CONNECTOR (PC BOARD) 2P

COMBINATION PARTS

CP501	1-466-376-11	CONVERTER UNIT, DC-DC
CP901	1-466-378-11	INVERTER UNIT

DIODE

D301	8-719-105-91	DIODE RD5.6M-B2
D304	8-719-400-18	DIODE MA152WK
D305	8-719-800-76	DIODE 1SS226
D501	8-719-800-76	DIODE 1SS226
D502	8-719-800-76	DIODE 1SS226
D503	8-719-800-76	DIODE 1SS226
D504	8-719-800-76	DIODE 1SS226
D505	8-719-911-06	DIODE 1SS106

FUSE

F501	△.1-532-637-00	LINK, IC ICP-N25 1.0A
------	----------------	-----------------------

IC

IC301	8-759-981-99	IC RC4560M
IC302	8-759-501-41	IC SM5840BS
IC303	8-759-981-99	IC RC4560M
IC304	8-759-981-82	IC RC3414M
IC501	8-752-038-71	IC CXA1127AM
IC502	8-759-990-55	IC CXA8006M
IC503	8-752-039-31	IC CXA1418N
IC504	8-752-818-81	IC CXP80524-022Q
IC505	8-759-500-05	IC MSM6338MS-K
IC506	8-759-507-26	IC RH5RA51AA
IC507	8-759-940-45	IC S-8054HN-CB
IC509	8-759-981-65	IC LM2903M
IC510	8-759-929-26	IC TL431CPS
IC511	8-759-998-10	IC MB3854
IC512	8-759-981-65	IC LM2903M

Note:
The components identified by mark △ or dotted line with mark △ are critical for safety. Replace only with part number specified.

Note:
Les composants identifiés par une marque △ sont critiques pour la sécurité. Ne les remplacer que par une pièce portant le numéro spécifié.

Ref.No	Part No.	Description	Remark	Ref.No	Part No.	Description	Remark
IC513	8-759-981-69	IC LM2904M		R118	1-216-833-11	METAL GLAZE 10K 5%	1/16W
IC514	8-759-031-60	IC SC7SU04FER		R119	1-216-011-00	METAL GLAZE 27 5%	1/10W
IC515	8-752-339-43	IC CXD2601AQ		R120	1-216-823-11	METAL GLAZE 1.5K 5%	1/16W
IC516	8-752-326-24	IC CXK58257M-12L		R127	1-216-833-11	METAL GLAZE 10K 5%	1/16W
IC517	8-759-931-43	IC SN74LS624NS		R128	1-216-833-11	METAL GLAZE 10K 5%	1/16W
IC518	8-759-981-69	IC LM2904M		R201	1-216-675-11	METAL CHIP 10K 0.50%	1/10W
IC519	8-759-031-60	IC SC7SU04FER		R202	1-216-643-11	METAL CHIP 470 0.50%	1/10W
IC520	8-759-031-60	IC SC7SU04FER		R203	1-216-667-11	METAL CHIP 4.7K 0.50%	1/10W
IC521	8-759-031-60	IC SC7SU04FER		R204	1-216-691-11	METAL CHIP 47K 0.50%	1/10W
IC525	8-759-710-79	IC NJM2107F		R205	1-216-845-11	METAL GLAZE 100K 5%	1/16W
<u>JACK</u>				R206	1-216-685-11	METAL CHIP 27K 0.50%	1/10W
J301	*1-562-974-51	JACK (MIC/LINE IN)		R207	1-216-651-11	METAL CHIP 1K 0.50%	1/10W
J302	*1-562-974-61	JACK (LINE OUT)		R208	1-216-651-11	METAL CHIP 1K 0.50%	1/10W
J303	*1-562-974-41	JACK (PHONES)		R209	1-216-651-11	METAL CHIP 1K 0.50%	1/10W
J501	1-569-966-11	JACK, DC (DC IN 9V)		R210	1-216-817-11	METAL GLAZE 470 5%	1/16W
<u>COIL</u>				R211	1-216-821-11	METAL GLAZE 1K 5%	1/16W
L101	1-410-997-31	INDUCTOR CHIP 2.2UH		R212	1-216-835-11	METAL GLAZE 15K 5%	1/16W
L102	1-410-997-31	INDUCTOR CHIP 2.2UH		R213	1-216-813-11	METAL GLAZE 220 5%	1/16W
L103	1-410-997-31	INDUCTOR CHIP 2.2UH		R214	1-216-841-11	METAL GLAZE 47K 5%	1/16W
L201	1-410-997-31	INDUCTOR CHIP 2.2UH		R215	1-216-833-11	METAL GLAZE 10K 5%	1/16W
L202	1-410-997-31	INDUCTOR CHIP 2.2UH		R216	1-216-833-11	METAL GLAZE 10K 5%	1/16W
L203	1-410-997-31	INDUCTOR CHIP 2.2UH		R217	1-216-845-11	METAL GLAZE 100K 5%	1/16W
L302	1-410-198-51	INDUCTOR CHIP 3.3UH		R218	1-216-833-11	METAL GLAZE 10K 5%	1/16W
L303	1-410-997-31	INDUCTOR CHIP 2.2UH		R219	1-216-011-00	METAL GLAZE 27 5%	1/10W
L304	1-410-997-31	INDUCTOR CHIP 2.2UH		R220	1-216-823-11	METAL GLAZE 1.5K 5%	1/16W
L501	1-412-137-11	INDUCTOR 10UH		R227	1-216-833-11	METAL GLAZE 10K 5%	1/16W
L502	1-412-137-11	INDUCTOR 10UH		R228	1-216-833-11	METAL GLAZE 10K 5%	1/16W
L503	1-412-137-11	INDUCTOR 10UH		R301	1-216-848-11	METAL GLAZE 180K 5%	1/16W
L504	1-412-137-11	INDUCTOR 10UH		R302	1-216-850-11	METAL GLAZE 270K 5%	1/16W
L505	1-410-997-31	INDUCTOR CHIP 2.2UH		R303	1-216-845-11	METAL GLAZE 100K 5%	1/16W
<u>TRANSISTOR</u>				R304	1-216-814-11	METAL GLAZE 270 5%	1/16W
Q101	8-729-159-64	TRANSISTOR 2SD596		R305	1-216-841-11	METAL GLAZE 47K 5%	1/16W
Q102	8-729-159-64	TRANSISTOR 2SD596		R307	1-216-809-11	METAL GLAZE 100 5%	1/16W
Q201	8-729-159-64	TRANSISTOR 2SD596		R308	1-216-809-11	METAL GLAZE 100 5%	1/16W
Q202	8-729-159-64	TRANSISTOR 2SD596		R309	1-216-809-11	METAL GLAZE 100 5%	1/16W
Q301	8-729-159-64	TRANSISTOR 2SD596		R310	1-216-809-11	METAL GLAZE 100 5%	1/16W
Q302	8-729-141-48	TRANSISTOR 2SB624-BV345		R311	1-216-841-11	METAL GLAZE 47K 5%	1/16W
Q303	8-729-402-19	TRANSISTOR XN6501		R501	1-216-837-11	METAL GLAZE 22K 5%	1/16W
Q501	8-729-140-75	TRANSISTOR 2SD999-CLCK		R502	1-216-837-11	METAL GLAZE 22K 5%	1/16W
Q502	8-729-140-75	TRANSISTOR 2SD999-CLCK		R503	1-216-813-11	METAL GLAZE 220 5%	1/16W
Q503	8-729-901-01	TRANSISTOR DTC144EK		R504	1-216-813-11	METAL GLAZE 220 5%	1/16W
Q505	8-729-271-23	TRANSISTOR 2SC2712		R505	1-216-833-11	METAL GLAZE 10K 5%	1/16W
Q506	8-729-900-53	TRANSISTOR DTC114EK		R506	1-216-833-11	METAL GLAZE 10K 5%	1/16W
Q507	8-729-422-18	TRANSISTOR XN4315		R507	1-216-833-11	METAL GLAZE 10K 5%	1/16W
<u>RESISTOR</u>				R508	1-216-833-11	METAL GLAZE 10K 5%	1/16W
R101	1-216-675-11	METAL CHIP 10K 0.50%	1/10W	R509	1-216-833-11	METAL GLAZE 10K 5%	1/16W
R102	1-216-643-11	METAL CHIP 470 0.50%	1/10W	R510	1-216-838-11	METAL GLAZE 27K 5%	1/16W
R103	1-216-667-11	METAL CHIP 4.7K 0.50%	1/10W	R511	1-216-838-11	METAL GLAZE 27K 5%	1/16W
R104	1-216-691-11	METAL CHIP 47K 0.50%	1/10W	R512	1-216-838-11	METAL GLAZE 27K 5%	1/16W
R105	1-216-845-11	METAL GLAZE 100K 5%	1/16W	R513	1-216-819-11	METAL GLAZE 680 5%	1/16W
R106	1-216-685-11	METAL CHIP 27K 0.50%	1/10W	R514	1-217-806-11	METAL GLAZE 1 5%	1/8W
R107	1-216-651-11	METAL CHIP 1K 0.50%	1/10W	R515	1-217-806-11	METAL GLAZE 1 5%	1/8W
R108	1-216-651-11	METAL CHIP 1K 0.50%	1/10W	R516	1-216-833-11	METAL GLAZE 10K 5%	1/16W
R109	1-216-651-11	METAL CHIP 1K 0.50%	1/10W	R517	1-216-833-11	METAL GLAZE 10K 5%	1/16W
R110	1-216-817-11	METAL GLAZE 470 5%	1/16W	R518	1-216-833-11	METAL GLAZE 10K 5%	1/16W
R111	1-216-821-11	METAL GLAZE 1K 5%	1/16W	R519	1-216-829-11	METAL GLAZE 4.7K 5%	1/16W
R112	1-216-835-11	METAL GLAZE 15K 5%	1/16W	R520	1-216-837-11	METAL GLAZE 22K 5%	1/16W
R113	1-216-813-11	METAL GLAZE 220 5%	1/16W	R521	1-216-821-11	METAL GLAZE 1K 5%	1/16W
R114	1-216-841-11	METAL GLAZE 47K 5%	1/16W	R522	1-216-845-11	METAL GLAZE 100K 5%	1/16W
R115	1-216-833-11	METAL GLAZE 10K 5%	1/16W	R523	1-216-845-11	METAL GLAZE 100K 5%	1/16W
R116	1-216-833-11	METAL GLAZE 10K 5%	1/16W	R524	1-216-845-11	METAL GLAZE 100K 5%	1/16W
R117	1-216-845-11	METAL GLAZE 100K 5%	1/16W	R525	1-216-837-11	METAL GLAZE 22K 5%	1/16W
				R526	1-216-837-11	METAL GLAZE 22K 5%	1/16W
				R527	1-216-837-11	METAL GLAZE 22K 5%	1/16W
				R528	*1-216-837-11	METAL GLAZE 22K 5%	1/16W

MAIN

Ref.No	Part No.	Description	Remark
R529	1-216-837-11	METAL GLAZE 22K	5% 1/16W
R530	1-216-845-11	METAL GLAZE 100K	5% 1/16W
R531	1-216-837-11	METAL GLAZE 22K	5% 1/16W
R532	1-216-818-11	METAL GLAZE 560	5% 1/16W
R533	1-216-818-11	METAL GLAZE 560	5% 1/16W
R534	1-216-837-11	METAL GLAZE 22K	5% 1/16W
R535	1-216-837-11	METAL GLAZE 22K	5% 1/16W
R536	1-216-837-11	METAL GLAZE 22K	5% 1/16W
R537	1-216-837-11	METAL GLAZE 22K	5% 1/16W
R538	1-216-699-11	METAL CHIP 100K	0.50% 1/10W
R539	1-216-841-11	METAL GLAZE 47K	5% 1/16W
R540	1-216-854-11	METAL GLAZE 560K	5% 1/16W
R541	1-216-847-11	METAL GLAZE 150K	5% 1/16W
R542	1-216-827-11	METAL GLAZE 3.3K	5% 1/16W
R543	1-216-294-11	METAL GLAZE 30K	5% 1/16W
R544	1-216-064-00	METAL GLAZE 4.3K	5% 1/10W
R545	1-216-820-11	METAL GLAZE 820	5% 1/16W
R546	1-216-698-11	METAL CHIP 91K	0.50% 1/10W
R547	1-216-683-11	METAL CHIP 22K	0.50% 1/10W
R548	1-216-685-11	METAL CHIP 27K	0.50% 1/10W
R549	1-216-829-11	METAL GLAZE 4.7K	5% 1/16W
R550	1-216-829-11	METAL GLAZE 4.7K	5% 1/16W
R551	1-216-811-11	METAL GLAZE 150	5% 1/16W
R552	1-216-834-11	METAL GLAZE 12K	5% 1/16W
R553	1-216-841-11	METAL GLAZE 47K	5% 1/16W
R554	1-216-839-11	METAL GLAZE 33K	5% 1/16W
R555	1-216-683-11	METAL CHIP 22K	0.50% 1/10W
R556	1-216-683-11	METAL CHIP 22K	0.50% 1/10W
R557	1-216-839-11	METAL GLAZE 33K	5% 1/16W
R558	1-216-821-11	METAL GLAZE 1K	5% 1/16W
R559	1-216-679-11	METAL CHIP 15K	0.50% 1/10W
R560	1-216-675-11	METAL CHIP 10K	0.50% 1/10W
R561	1-216-839-11	METAL GLAZE 33K	5% 1/16W
R562	1-216-839-11	METAL GLAZE 33K	5% 1/16W
R563	1-216-635-11	METAL CHIP 220	0.50% 1/10W
R564	1-216-171-00	METAL GLAZE 75	5% 1/8W
R565	1-216-833-11	METAL GLAZE 10K	5% 1/16W
R566	1-216-841-11	METAL GLAZE 47K	5% 1/16W
R567	1-216-839-11	METAL GLAZE 33K	5% 1/16W
R568	1-216-809-11	METAL GLAZE 100	5% 1/16W
R570	1-216-839-11	METAL GLAZE 33K	5% 1/16W
R571	1-216-821-11	METAL GLAZE 1K	5% 1/16W
R572	1-216-679-11	METAL CHIP 15K	0.50% 1/10W
R573	1-216-675-11	METAL CHIP 10K	0.50% 1/10W
R574	1-216-839-11	METAL GLAZE 33K	5% 1/16W
R575	1-216-839-11	METAL GLAZE 33K	5% 1/16W
R576	1-216-635-11	METAL CHIP 220	0.50% 1/10W
R577	1-216-699-11	METAL CHIP 100K	0.50% 1/10W
R578	1-216-699-11	METAL CHIP 100K	0.50% 1/10W
R579	1-216-690-11	METAL CHIP 43K	0.50% 1/10W
R580	1-216-699-11	METAL CHIP 100K	0.50% 1/10W
R581	1-216-857-11	METAL GLAZE 1M	5% 1/16W
R582	1-216-794-11	METAL GLAZE 5.6	5% 1/16W
R583	1-216-794-11	METAL GLAZE 5.6	5% 1/16W
R584	1-216-794-11	METAL GLAZE 5.6	5% 1/16W
R585	1-216-841-11	METAL GLAZE 47K	5% 1/16W
R586	1-216-041-00	METAL GLAZE 470	5% 1/10W
R587	1-216-809-11	METAL GLAZE 100	5% 1/16W
R588	1-216-809-11	METAL GLAZE 100	5% 1/16W
R589	1-216-809-11	METAL GLAZE 100	5% 1/16W
R590	1-216-829-11	METAL GLAZE 4.7K	5% 1/16W
R591	1-216-845-11	METAL GLAZE 100K	5% 1/16W
R592	1-216-837-11	METAL GLAZE 22K	5% 1/16W
R593	1-216-817-11	METAL GLAZE 470	5% 1/16W
R594	1-216-817-11	METAL GLAZE 470	5% 1/16W

Ref.No	Part No.	Description	Remark
R595	1-216-817-11	METAL GLAZE 470	5% 1/16W
R596	1-216-817-11	METAL GLAZE 470	5% 1/16W
R597	1-216-838-11	METAL GLAZE 27K	5% 1/16W
R598	1-216-839-11	METAL GLAZE 33K	5% 1/16W
R599	1-216-833-11	METAL GLAZE 10K	5% 1/16W
R600	1-216-817-11	METAL GLAZE 470	5% 1/16W
R701	1-216-825-11	METAL GLAZE 2.2K	5% 1/16W
R702	1-216-833-11	METAL GLAZE 10K	5% 1/16W
R703	1-216-821-11	METAL GLAZE 1K	5% 1/16W
R704	1-216-821-11	METAL GLAZE 1K	5% 1/16W
R705	1-216-009-00	METAL GLAZE 22	5% 1/10W
R706	1-216-845-11	METAL GLAZE 100K	5% 1/16W
R707	1-216-089-00	METAL GLAZE 47K	5% 1/10W
R708	1-216-845-11	METAL GLAZE 100K	5% 1/16W
R709	1-216-113-00	METAL GLAZE 470K	5% 1/10W
R710	1-216-849-11	METAL GLAZE 220K	5% 1/16W
R711	1-216-837-11	METAL GLAZE 22K	5% 1/16W
R712	1-216-821-11	METAL GLAZE 1K	5% 1/16W
R713	1-216-826-11	METAL GLAZE 2.7K	5% 1/16W
R714	1-216-837-11	METAL GLAZE 22K	5% 1/16W
R715	1-216-838-11	METAL GLAZE 27K	5% 1/16W
R716	1-216-843-11	METAL GLAZE 68K	5% 1/16W
R717	1-216-821-11	METAL GLAZE 1K	5% 1/16W

VARIABLE RESISTOR

RV301	1-241-159-11	RES, VAR, CARBON 20K/20K (REC LEVEL)
RV302	1-241-159-11	RES, VAR, CARBON 20K/20K (VOLUME)
RV501	1-238-666-11	RES, ADJ, CERMET 47K

SWITCH

S301	1-570-182-11	SWITCH, SLIDE (INPUT SELECT)
S302	1-570-087-11	SWITCH, SLIDE (MIC ATT)

CRYSTAL

X501	1-579-064-11	VIBRATOR, CRYSTAL (9.408MHz)
X502	1-567-814-11	VIBRATOR, CRYSTAL (24.576MHz)
X503	1-567-815-11	VIBRATOR, CRYSTAL (22.5792MHz)
X504	1-567-816-11	VIBRATOR, CRYSTAL (18.816MHz)

Ref.No	Part No.	Description	Remark
MISCELLANEOUS *****			
	1-466-369-11	RF MODULE	
	1-572-408-11	SWITCH, ENCAPSULATED	
	1-590-202-11	WIRE (WITH TERMINAL)	
	1-808-281-41	SENSOR (DEW)	
CN901	1-575-917-11	CABLE (WITH CONNECTOR) (REMOTE DIGITAL I/O)	
CP901	1-466-378-11	INVERTER UNIT	
EL901	1-519-621-11	ELECTRIC LUMINESCENCE	
M1001	1-541-777-11	MOTOR (WITH GEAR)	
ND901	1-550-598-11	DISPLAY PANEL, LIQUID CRYSTAL	
PM1001	1-454-326-00	SOLENOID, PLUNGER	
Q1001	8-729-925-30	SENSOR (END) (PT4810F)	
Q1002	8-729-925-30	SENSOR (END) (PT4810F)	
S1001	1-571-878-11	SWITCH, PUSH (2 KEY) (CASSETTE DET/REC PROOF)	
S1002	1-571-175-11	SWITCH, PUSH (AC POWER) (1 KEY) (CASSETTE CONTROL LOCK)	



HARDWARE LIST

#1	7-627-850-37	SCREW,PRECISION +P 1.4X1.4
#2	7-627-850-47	SCREW,PRECISION +P 1.4X1.6
#3	7-627-551-47	SCREW,PRECISION +P 1.4X1.4
#4	7-627-850-17	SCREW,PRECISION +P 1.4X2.5
#5	7-627-551-17	SCREW,PRECISION +P 1.4X2
#6	7-627-551-77	SCREW,PRECISION +P 1.4X4 TYPE1
#7	7-627-451-07	SCREW,PRECISION +K 1.4X1.6

Ref.No	Part No.	Description	Remark
ACCESSORIES & PACKING MATERIALS *****			
△	1-465-522-11	AC ADAPTOR / CHARGE (ACP-D33) (TOURIST, E)	
△	1-465-524-11	AC ADAPTOR / CHARGE (ACP-D30) (AEP)	
△	1-465-525-11	AC ADAPTOR / CHARGE (ACP-D3U) (US)	
△	1-465-527-11	AC ADAPTOR / CHARGE (ACP-D3U) (CND)	
△	1-465-528-11	AC ADAPTOR / CHARGE (ACP-D30) (UK)	
△	1-693-103-11	AC ADAPTOR / CHARGE (ACP-D33) (EA)	
△	1-693-104-11	AC ADAPTOR / CHARGE (ACP-D30) (AUS)	
△	1-528-333-11	BATTERY PACK (BP-D3) (US, CND, UK, E, AUS)	
△	1-528-334-11	BATTERY PACK (BP-D3) (AEP, EA)	
△	1-569-007-11	ADAPTER, CONVERSION 2P (E)	
	1-569-008-11	ADAPTER, CONVERSION 2P (EA)	
	1-590-161-11	CORD, CONNECTION	
	1-590-264-11	CABLE, OPTICAL BIGITAL (POC-DA12)	
*	3-361-185-01	CUSHION (UPPER) (EXCEPT AUS, EA)	
*	3-361-186-01	CUSHION (LOWER) (EXCEPT AUS, EA)	
*	3-361-187-01	INDIVIDUAL CARTON (UK)	
*	3-366-519-01	INDIVIDUAL CARTON (US, CND, AEP, E)	
*	3-379-544-01	CUSHION (AUS, EA)	
*	3-379-547-01	INDIVIDUAL CARTON (AUS, EA)	
	3-361-189-01	CASE, CARRYING	
	3-701-630-00	BAG, POLYETHYLENE	
	3-752-456-11	MANUAL, INSTRUCTION (ENGLISH, FRENCH, SPANISH, PORTUGUESE)(AEP)	
	3-752-456-21	MANUAL, INSTRUCTION (ENGLISH)(US, AUS)	
	3-752-456-41	MANUAL, INSTRUCTION (GERMAN, DUTCH, SWEDISH, ITALIAN) (AEP)	
	3-752-456-51	MANUAL, INSTRUCTION (KOREAN) (TOURIST)	
	3-752-456-61	MANUAL, INSTRUCTION (ENGLISH, FRENCH, SPANISH, PORTUGUESE)(TOURIST, E)	
	3-752-456-81	MANUAL, INSTRUCTION (ENGLISH, FRENCH, SPANISH, PORTUGUESE)(CND, UK, EA)	
	3-752-456-91	MANUAL, INSTRUCTION (GERMAN, DUTCH, SWEDISH, ITALIAN)(EA)	

• Abbreviations

CND : Canadian
AUS : Australian
EA : Saudi Arabia

Note:
The components identified by mark  or dotted line with mark  are critical for safety. Replace only with part number specified.

Note:
Les composants identifiés par une marque  sont critiques pour la sécurité. Ne les remplacer que par une pièce portant le numéro spécifié.

TCD-D3

SONY[®] SERVICE MANUAL

US Model
Canadian Model
AEP Model
UK Model
E Model
Australian Model

SUPPLEMENT-1

File This Supplement with Service Manual.

1. Guide of Change the Servicing Assembly Parts for Single Parts.
2. Guide of Servicing Assembly Parts.
3. Guide of Change Parts.

6-6. MD ASSEMBLY 3
(MT-D3-47)

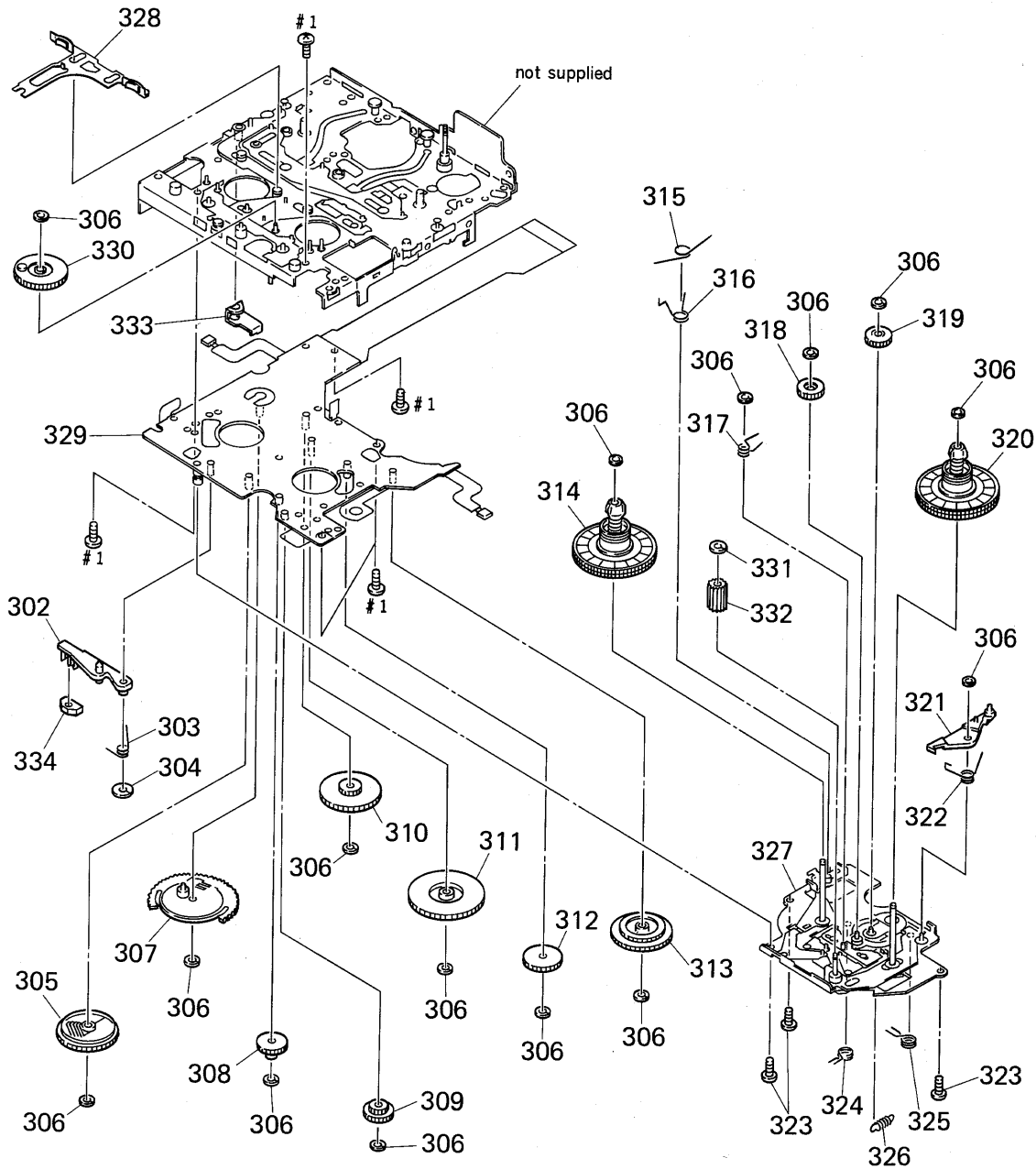

Ref.No	Part No.	Description	Remark
302	X-3344-956-3	LEVER (SOLENOID) ASSY	
303	3-361-117-01	SPRING, TORSION	
304	3-311-815-11	WASHER, POLYETHYLENE	
305	X-3344-966-3	GEAR (A) ASSY, CAM	
306	3-315-384-11	WASHER, STOPPER (1.2-2.5) (T=0.25)	
307	X-3344-967-5	GEAR (LOADING) ASSY	
308	3-360-832-02	GEAR (MODE D)	
309	3-360-830-02	GEAR (MODE C)	
310	3-360-828-01	GEAR (E)	
311	3-360-883-02	GEAR (D)	
312	3-360-827-01	GEAR (C)	
313	3-360-824-01	GEAR (B)	
314	X-3344-960-4	TABLE (S) ASSY, REEL	
315	3-361-104-01	SPRING, TORSION	
316	3-361-116-03	SPRING, TORSION	
317	3-361-103-31	SPRING, TORSION	
318	3-360-826-02	GEAR (FF/REW)	

Ref.No	Part No.	Description	Remark
319	3-360-825-01	GEAR (FR)	
320	X-3344-961-4	TABLE (T) ASSY, REEL	
321	3-360-849-02	LEVER (T LOCK)	
322	3-361-114-01	SPRING, TORSION	
323	3-703-502-01	SCREW, +PWH 1.4X1.6	
324	3-361-102-01	SPRING, TORSION	
325	3-360-896-03	SPRING, TORSION	
326	3-370-921-02	SPRING, TORSION	
327	X-3344-973-5	CHASSIS (REEL) ASSY	
328	X-3344-959-1	LEVER (SOFT BRAKE) ASSY	
329	X-3363-604-1	CHASSIS (SUB) ASSY	
330	3-360-886-03	GEAR (B), CAM	
331	3-321-813-01	WASHER, COTTER POLYETHYLENE	
332	3-360-831-02	GEAR (MODE E)	
333	3-365-425-02	REINFORCEMENT (CHASSIS, REEL)	
334	1-454-326-31	ACTUATOR	
#1	7-627-850-37	SCREW, PRECISION +P 1.4X1.4	

• SERVICING ASSEMBLY PARTS

Service Manual : page 61

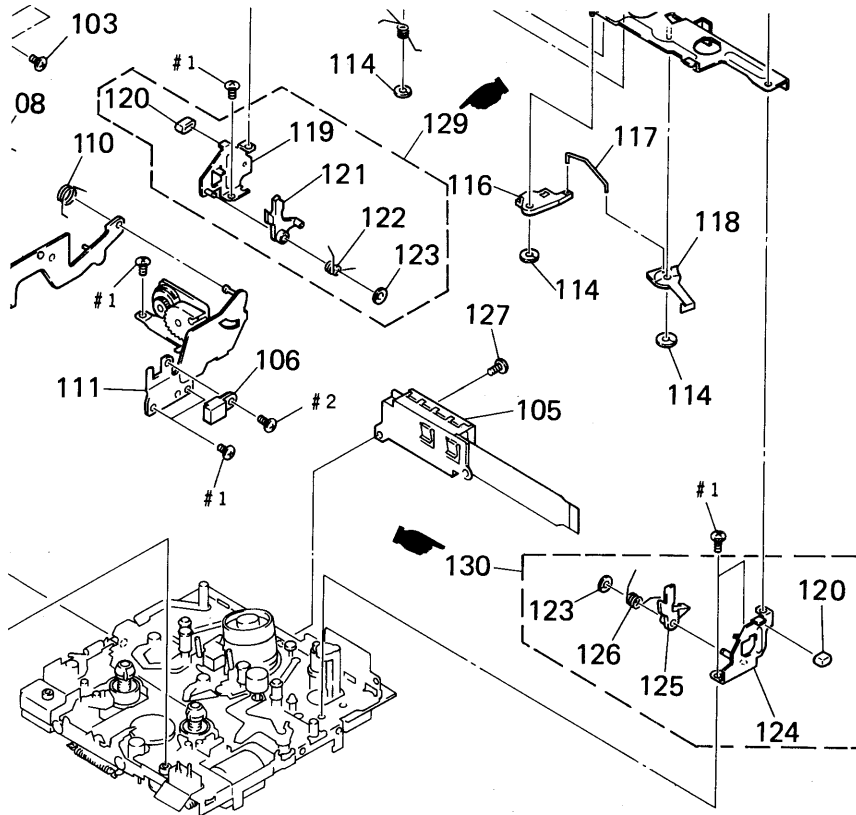

Ref.No	Part No.	Description	Remark
129	X-3363-602-1	BRACKET (CLB) BLOCK ASSY	
130	X-3363-603-1	BRACKET (CRB) BLOCK ASSY	

Service Manual : page 62

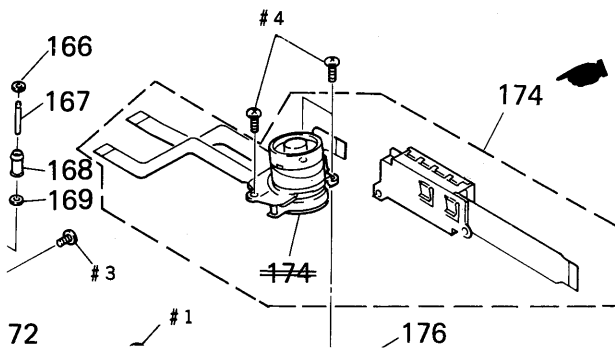

Ref.No	Part No.	Description	Remark
174	X-3363-430-1	DRUM ASSY (Including RF MODULE)	

• CHANGE PARTS

Service Manual : page 62

Former Type		New Type		Remark
Ref.No	Part No.	Part No.	Description	
157	3-728-290-01	3-366-945-01	SCREW (M1.2×3)	
169	3-361-163-41	3-361-163-51	WASHER (1.3-3.2) T=0.25	
175	3-321-393-11	3-361-162-01	STOP RING (0.8-2.5) T=0.2	

Service Manual : page 63

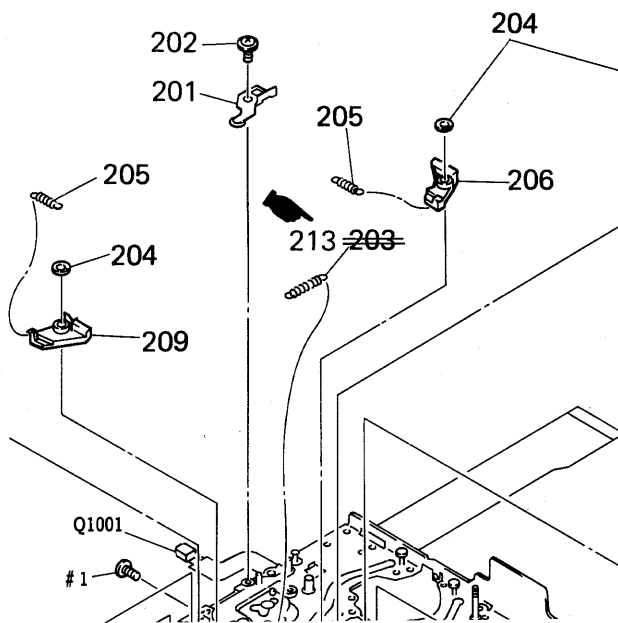

Former Type		New Type		Remark
Ref.No	Part No.	Part No.	Description	
203	3-361-101-01	DELETE		
212	X-3362-753-1	X-3363-605-1	MECHANISM DECK ASSY	
225	3-703-502-31	3-703-502-51	SCREW (1.4×4)	

9-955-978-12
[Including 9-955-978-83
9-955-978-86]

Sony Corporation
General Audio Group

English
92C0414-1
Printed in Japan
© 1992. 3